



中山市晶艺光电科技有限公司
ZHONGSHAN JEWELLY OPTOELECTRONIC TECHNOLOGY CO.,LTD.

样品承认书

品名： 44*78 共阳双色彩屏

规格： UL-4478-a-BEG-15R11G-2

编号： 2017-07

客户签字栏		
核准	审核	承认

本公司签字栏		
核准	审核	制作

地址：广东省中山市南区昌盛路4号

电话：0760-23886633 23886636 23886632

传真：0760-23886658

网址：www.jlul.com

电子邮箱：jinglei@jlul.com



PART NO.: UL-4478-a-BEG -15R11G-2

ELECTRICAL AND OPTICAL CHARACTERISTICS(Ta=25°C)

Chip		Lens Appearance	Absolute Maximum				Electro-optical Data(AT20mA)			
Emitted	Peak Wave Length		$\Delta \lambda$ (nm)	Pd (mW)	If (mA)	Peak (mA)	Vf (V)			IV (mcd)
							Min	Mean	Max	Typ.
Red	638-642	White Diff.	20	35	20	60	1.7	2.0	2.5	15-22
Yellow Green	570-572	White Diff	20	35	20	60	1.7	2.0	2.5	30-35

Remark: Viewing angle is the Off-axis angle at which the luminous intensity is half the axial luminous intensity.

ABSOLUTE MAXIMUM RATINGS(Ta=25°C)

Reverse Voltage.....5V

Reverse Current(V_R=5V).....20 μ A

Operating Temperature Range.....-25°C~+80°C

Storage Temperature Range.....-30°C~+80°C

Lead Soldering Temperature..... 260°C For 5 Seconds

PACKAGE DIMENSION:

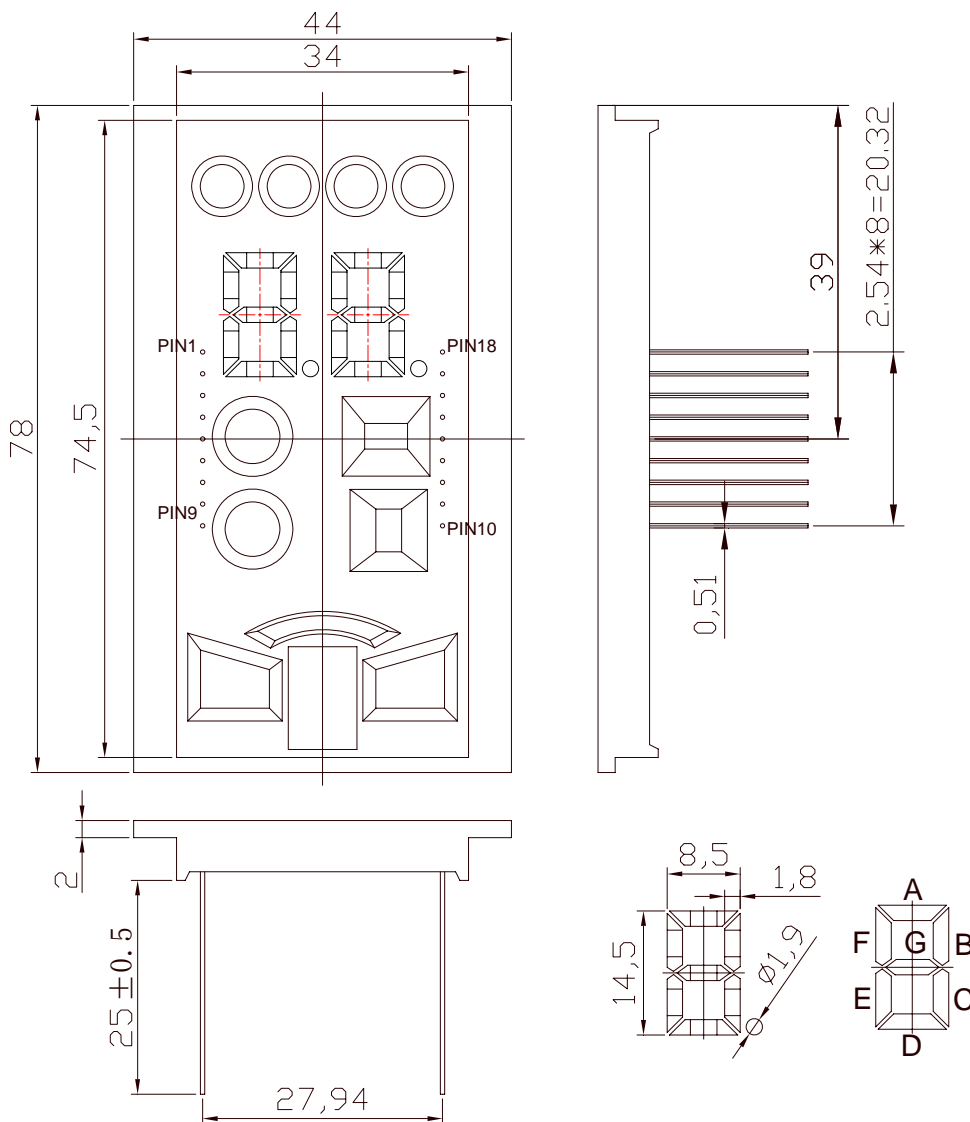



PART NO.: UL-4478-a-BEG-15G11G-2

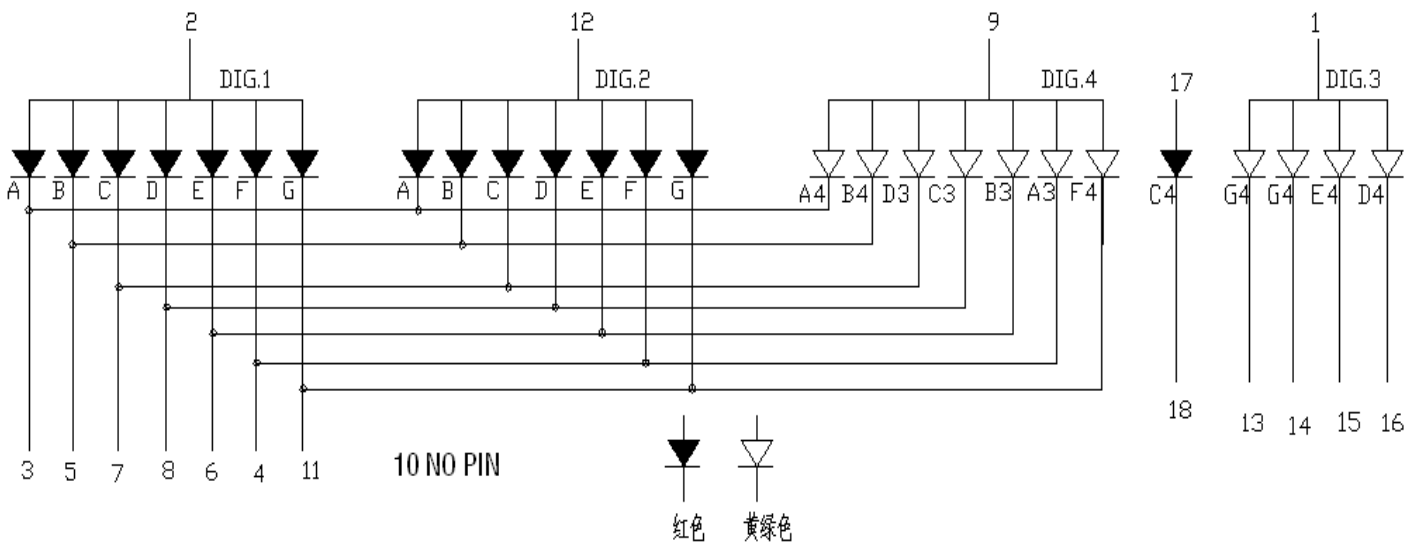
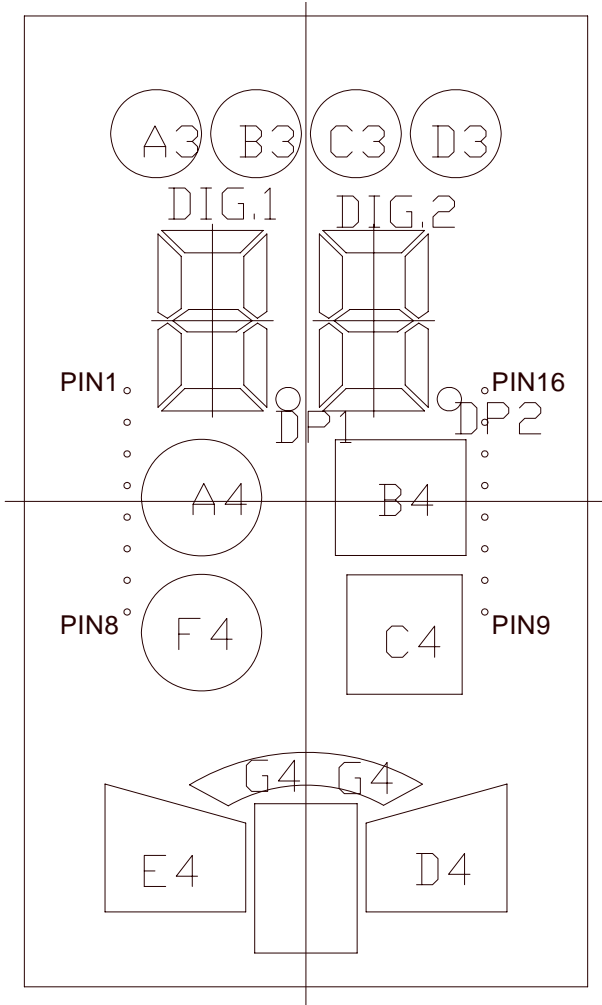



PART NO.: UL-4478-a-BEG-15R11G-2

TYPICAL ELECTRO-OPTICAL CHARACTERISTICS CURVE:

Color: Yellow Green

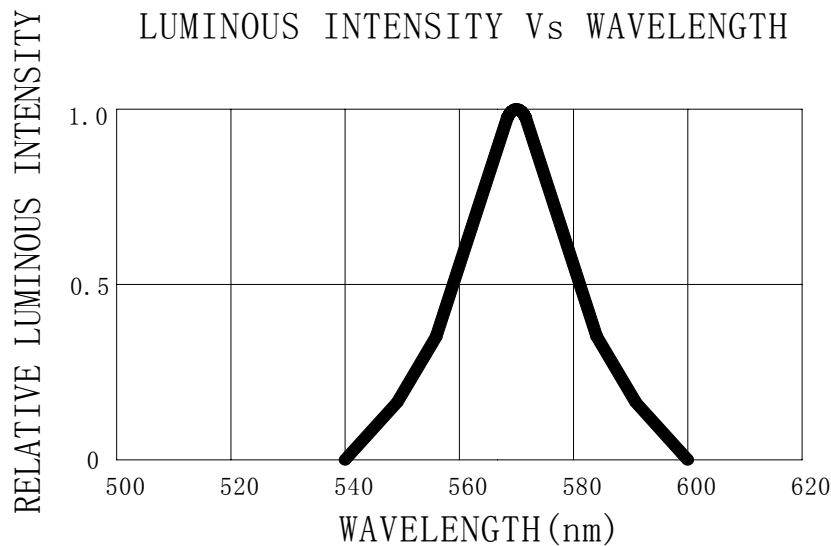
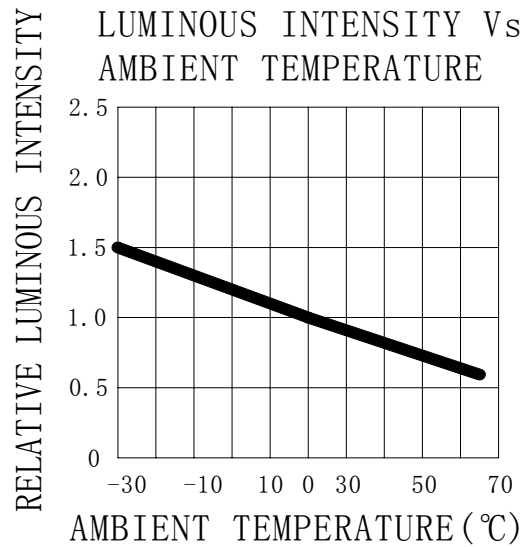
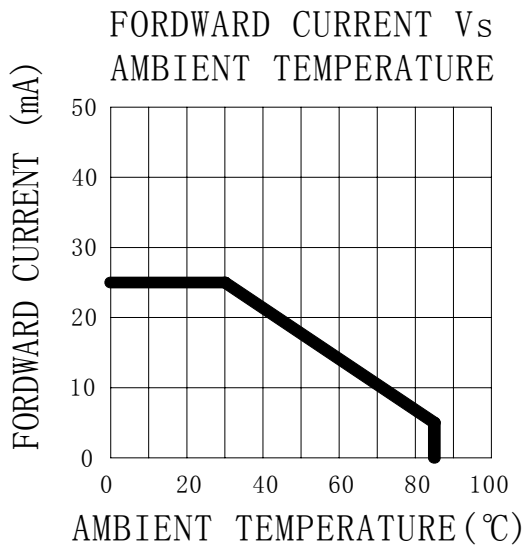
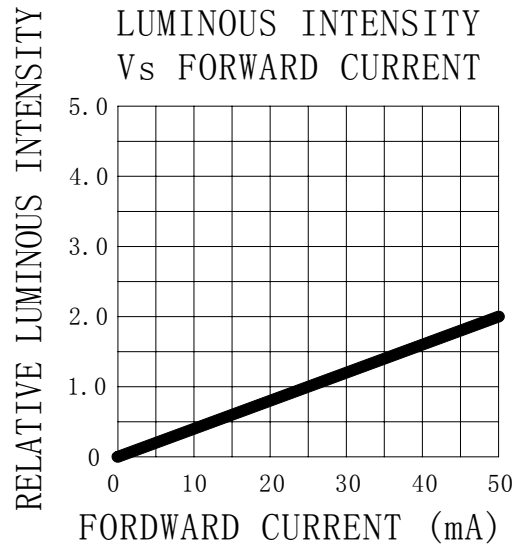
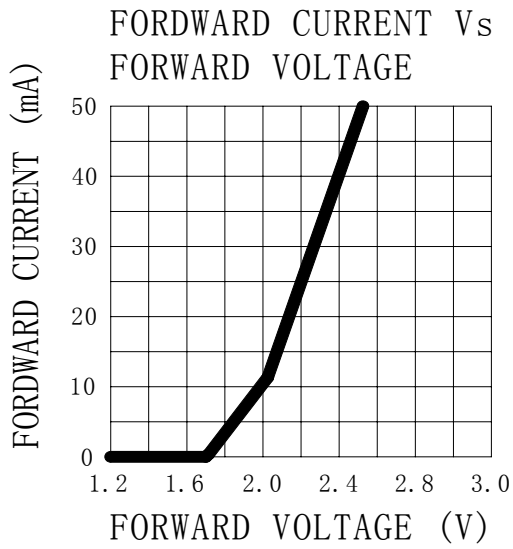



PART NO.: UL-4478-a-BEG-15R11G-2

TYPICAL ELECTRO-OPTICAL CHARACTERISTICS CURVE:

Color:Hi-Red

