



中山市晶艺光电科技有限公司
ZHONGSHAN JEWELLY OPTOELECTRONIC TECHNOLOGY CO.,LTD.

样品承认书

品名： 一位数码管 0.56”共阴红色

规格： ULS-5163AS26

编号： 2017-07

客户签字栏		
核准	审核	承认

本公司签字栏		
核准	审核	制作

地址：广东省中山市南区昌盛路4号

电话：0760-23886633 23886636 23886632

传真：0760-23886658

网址：www.jlul.com

电子邮箱：jinglei@jlul.com



PART NO.: ULS-5163AS26

ELECTRICAL AND OPTICAL CHARACTERISTICS(Ta=25°C)

Chip		Lens Appearance	Absolute Maximum				Electro-optical Data(AT20mA)			
Emitted	Peak Wave Length		$\Delta \lambda$ (nm)	Pd (mW)	If (mA)	Peak (mA)	Vf (V)			IV (mcd)
							Min	Typ	Max	Typ.
Red	630-635	White Diff.	30	35	20	60	1.7	2.0	2.5	30-35

Remark: Viewing angle is the Off-axis angle at which the luminous intensity is half the axial luminous intensity.

ABSOLUTE MAXIMUM RATINGS(Ta=25°C)

Reverse Voltage.....5V

Reverse Current(V_R=5V).....20 μ A

Operating Temperature Range.....-25°C~+80°C

Storage Temperature Range.....-30°C~+80°C

Lead Soldering Temperature..... 260°C For 5 Seconds

PACKAGE DIMENSION:

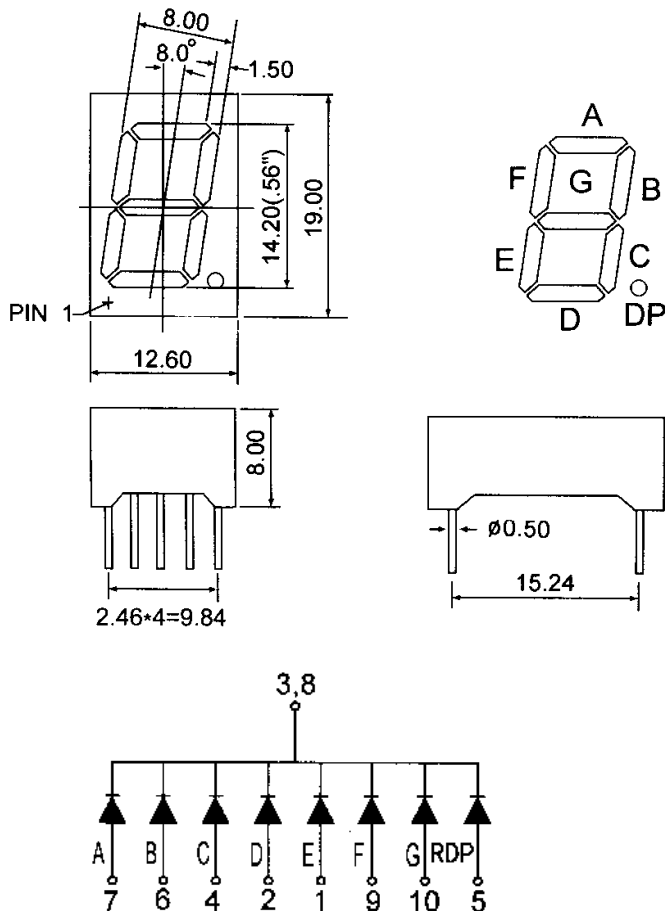

未注公差: ±0.2

客户名称:

工程确认:

日期:



PART NO.: ULS-5163AS26

TYPICAL ELECTRO-OPTICAL CHARACTERISTICS CURVE:

