

820M1 CONDITION MONITORING ACCELEROMETER

SPECIFICATIONS

- Piezoelectric Accelerometer
- $\pm 25g$ to $\pm 500g$ Dynamic Ranges
- Wide Bandwidth to 10,000Hz
- Superior Resolution to MEMS Devices
- Circuit Board Mountable, Reflow Solderable
- Low Cost, Superior Value

FEATURES

- Amplified $\pm 1.25V$ Signal Output
- 3.0 to 5.5Vdc Excitation Voltage
- Hermetically Sealed
- Piezo-Ceramic Crystal, Shear Mode
- -40° to $+125^{\circ}C$ Operating Range

APPLICATIONS

- Machine Health Monitoring
- Predictive Maintenance Installations
- Embedded Vibration Monitoring
- Impact & Shock Monitoring
- Data Loggers
- Bearing Installations

The Model 820M1 is a low cost, board mountable accelerometer designed for embedded condition monitoring and preventive maintenance applications. The piezo-electric accelerometer is available in ranges from $\pm 25g$ to $\pm 500g$ and features a flat frequency response up to $>10kHz$. The model 820M1 accelerometer feature a stable piezo-ceramic crystal in shear mode with low power electronics, sealed in a fully hermetic LCC package.

The PE technology incorporated in the 820M1 accelerometer has a proven track record for offering the reliable and long-term stable output required for condition monitoring applications. The accelerometer is designed and qualified for machine health monitoring and has superior Resolution, Dynamic Range and Bandwidth to MEMS devices.

MODEL 820M1 ACCELEROMETER

PERFORMANCE SPECIFICATIONS

All values are typical at +24°C, 80Hz and 3.3Vdc excitation unless otherwise stated. TE Connectivity reserves the right to update and change these specifications without notice.

Parameters

DYNAMIC

	±25	±50	±100	±200	±500	Notes
Range (g)	±25	±50	±100	±200	±500	
Sensitivity (mV/g)	50.0	25.0	12.5	6.3	2.5	±30%
Frequency Response (Hz)	6-6000	6-6000	6-6000	6-6000	6-6000	±1dB
Frequency Response (Hz)	2-10000	2-10000	2-10000	2-10000	2-10000	±3dB (see note 1 below)
Resonant Frequency (Hz)	>30000	>30000	>30000	>30000	>30000	
Non-Linearity (%FSO)	±2	±2	±2	±2	±2	
Transverse Sensitivity (%)	<5	<5	<5	<5	<5	Typical
Shock Limit (g)	10,000	10,000	10,000	10,000	10,000	
Residual Noise (mg RMS)	6.3	12.4	15.9	24.7	39.9	2Hz to 10kHz
Spectral Noise, 10Hz (µg√Hz)	98	193	248	384	620	
Spectral Noise, 100Hz (µg√Hz)	51	101	130	201	324	
Spectral Noise, 1kHz (µg√Hz)	45	89	114	176	285	

ELECTRICAL

Excitation Voltage (Vdc)	3.0 to 5.5 (see note 2 below)
Bias Voltage (Vdc)	Excitation Voltage / 2
Full Scale Output Voltage (V)	±1.25
Total Supply Current (µA)	62
Output Impedance (Ω)	<100
Warm-up Time (sec)	<1

ENVIRONMENTAL

Temperature Response (%)	See Typical Temperature Response Curves on Page 3
Operating Temperature (°C)	-40 to +125
Storage Temperature (°C)	-40 to +125
Humidity	Hermetically Sealed

PHYSICAL

Sensing Element	PZT (Lead Zirconate Titanate), Shear Mode
Case Material	Ceramic Base and Kovar Cover
Weight (grams)	1.2
Mounting	Solder Reflow

Calibration supplied: CS-SENS-0100 NIST Traceable Amplitude Calibration at 80Hz

¹ Proper mounting is critical for good performance to 10kHz. See operating manual for recommended installation instructions.

² The model 820M1 can be operated with 2.8V excitation but the full-scale range will be limited. See operating manual for details.

The information in this sheet has been carefully reviewed and is believed to be accurate; however, no responsibility is assumed for inaccuracies. Furthermore, this information does not convey to the purchaser of such devices any license under the patent rights to the manufacturer. TE Connectivity reserves the right to make changes without further notice to any product herein. TE Connectivity makes no warranty, representation or guarantee regarding the suitability of its product for any particular purpose, nor does TE Connectivity assume any liability arising out of the application or use of any product or circuit and specifically disclaims any and all liability, including without limitation consequential or incidental damages. Typical parameters can and do vary in different applications. All operating parameters must be validated for each customer application by customer's technical experts. TE Connectivity does not convey any license under its patent rights nor the rights of others.

BIAS TEMPERATURE SHIFT

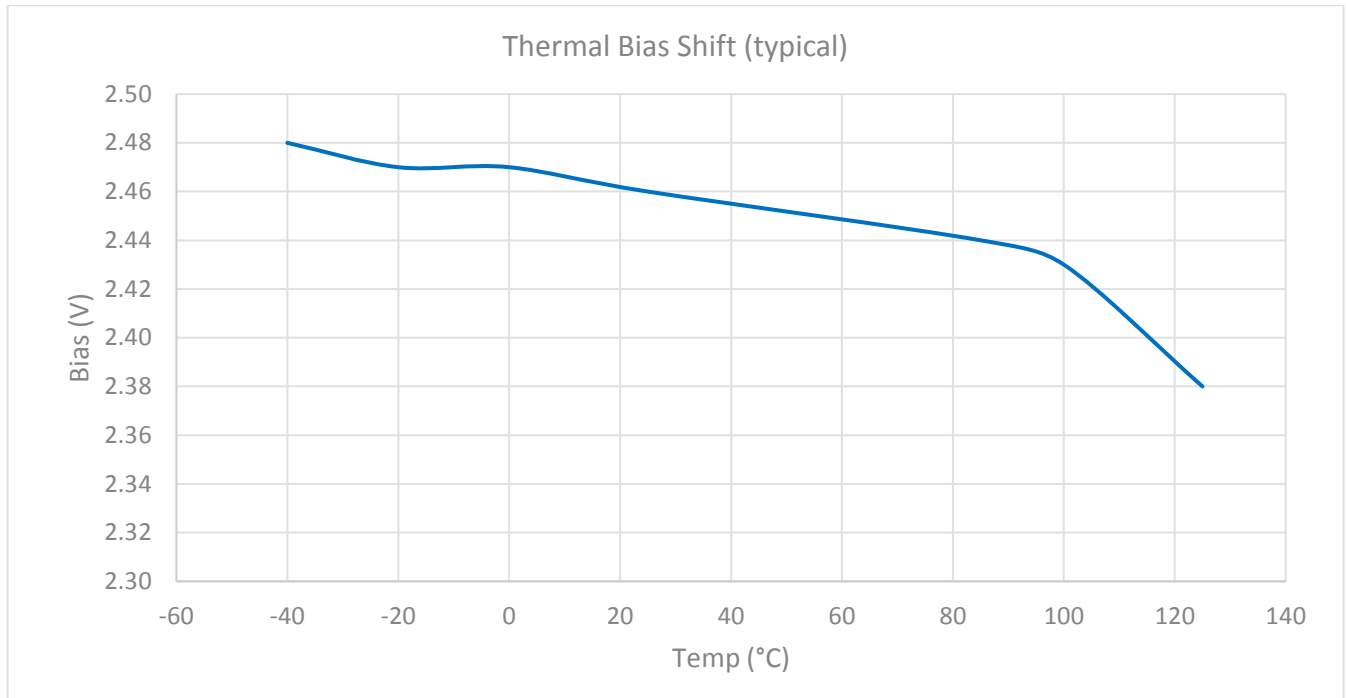

SENSITIVITY TEMPERATURE SHIFT

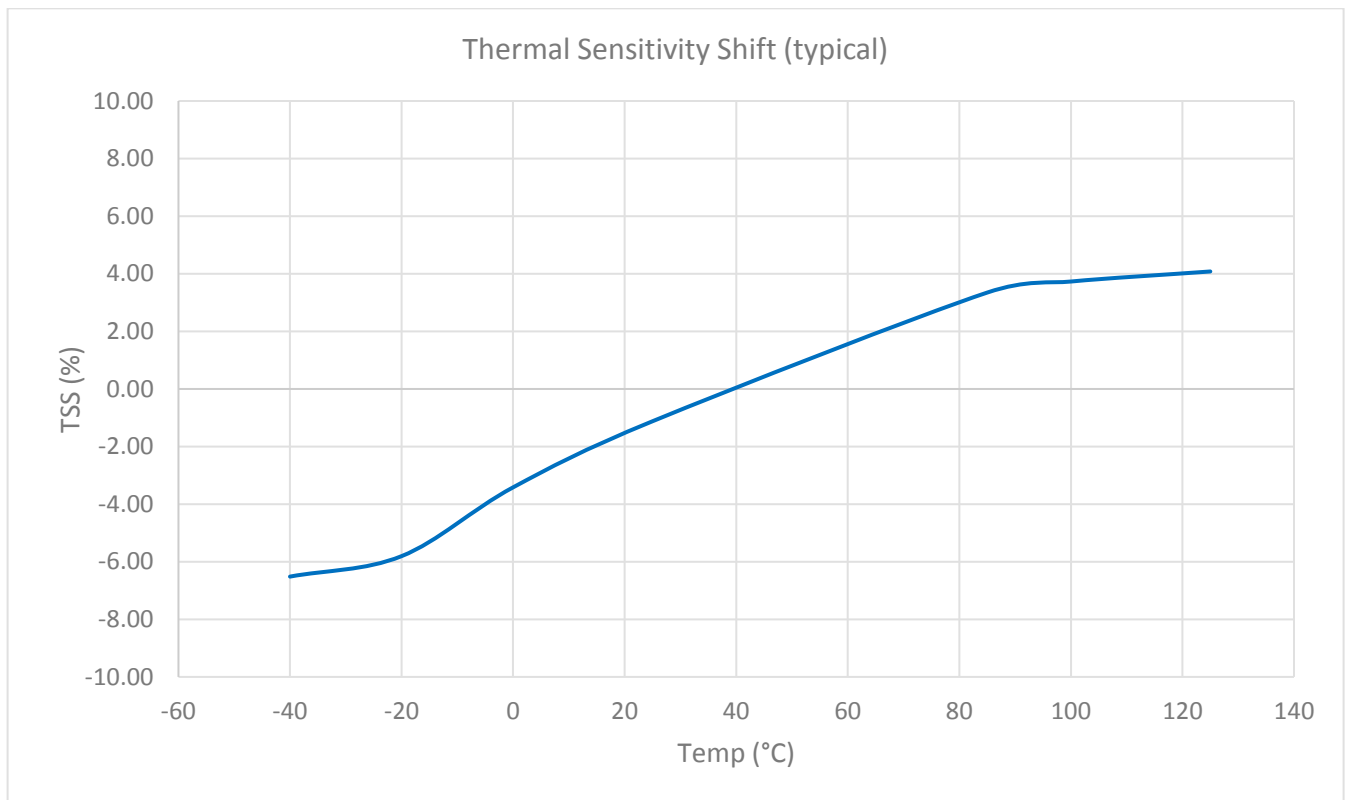

MODEL 820M1 ACCELEROMETER

DIMENSIONS

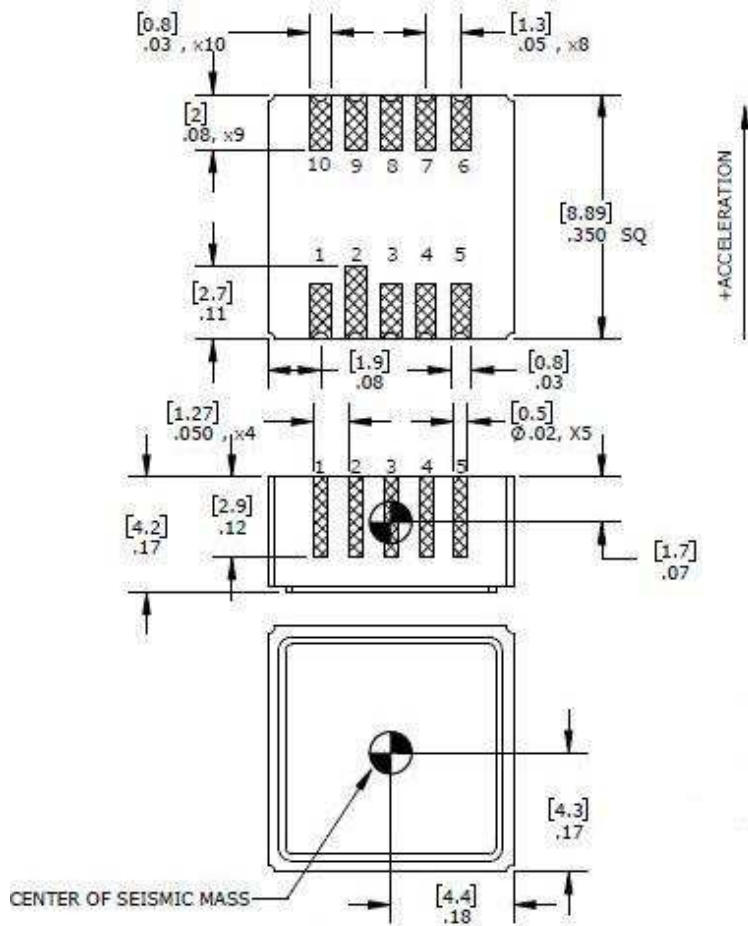

SCHEMATIC

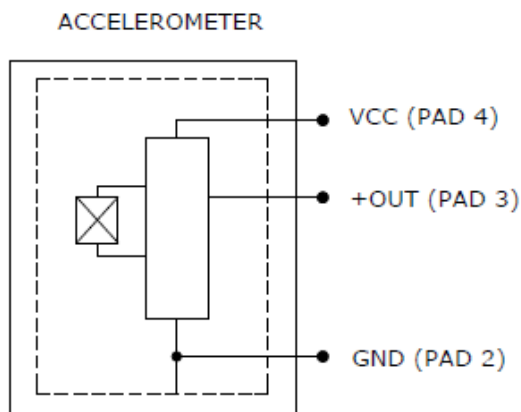

MODEL 820M1 ACCELEROMETER

ORDERING INFORMATION

820M1-GGGG

|_____ Range (0100 is 100g)

Part Number	Range
820M1-0025	25g
820M1-0050	50g
820M1-0100	100g
820M1-0200	200g
820M1-0500	500g