

MODEL 64C CRASH TEST ACCELEROMETER

SPECIFICATIONS

- **Advance Piezoresistive MEMS Sensor**
- **Next Generation Piezoresistive MEMS Sensor**
- **±50g to ±6000g Ranges**
- **Compliant to SAE-J211/J2570**
- **Compliant to ISO-6487**
- **High Over Range Protection**

APPLICATIONS

- Anthropomorphic Dummy Instrumentation
- Crush Zone Testing
- Auto Safety Testing Applications
- Shock and Impact Testing
- Transient Drop Testing

FEATURES

- 1% Transverse Sensitivity Option
- Wide bandwidth to >8kHz
- Standard <25mV ZMO
- Linearity <1%
- 10,000g Shock Protection
- 2-10Vdc Excitation
- Optimum Gas Damping
- Quick Warm-up Time

The TE Connectivity model 64C crash test accelerometer is a remarkable MEMS piezoresistive sensor specifically designed for auto safety testing in both crush zone and anthropomorphic dummy applications. The accelerometer features a full bridge output configuration with ideal gas damping tailored for outstanding shock survivability and a flat frequency response to >8kHz. The model 64C accelerometer has a standard cross-talk accuracy of <3% (with option for <1%), a standard ZMO of <±25mV and a linearity accuracy specification of <±1.0%.

The model 64C ATD dummy test accelerometer is offered in ranges from ±50 to ±6000g and has a standard operating temperature range of -40°C to +121°C. The nominal 4000Ω bridge impedance limits current draw resulting in quick warm-up time and minimal drift, unlike lower impedance designs on the market which are subject to much longer warm-up time due to gage heating effects.

TE Connectivity also supplies the calibration data in a user friendly excel format which enables high volume users to quickly upload the calibration information for each sensor installed.

Users of the model 64C accelerometer are strongly recommended to also review the model 64X accelerometer which is the latest evolution of the TE Connectivity 64 series crash test sensors.

MODEL 64C CRASH TEST ACCELEROMETER

PERFORMANCE SPECIFICATIONS

All values are typical at +24°C, 80Hz and 10Vdc excitation unless otherwise stated. TE Connectivity reserves the right to update and change these specifications without notice.

PARAMETERS

DYNAMIC							NOTES
Range (g)	±50	±100	±200	±500	±2000	±6000	
Sensitivity (mV/g) ¹	1.2-3.0	0.6-1.2	0.6-1.2	0.3-0.6	0.12-0.3	0.05-0.12	@10Vdc Excitation
Frequency Response (Hz)	0-1000 0-1400	0-1200 0-1600	0-1400 0-1900	0-2000 0-2800	0-6000 0-8000	0-6000 0-8000	±5% ±1dB
Natural Frequency (Hz)	4000	6000	8000	11000	28000	28000	
Transverse Sensitivity (%)	<3	<3	<3	<3	<3	<3	<1% on 'T' Option
Non-Linearity (% of reading)	±1	±1	±1	±1	±1	±1	
Damping Ratio	0.5	0.5	0.5	0.3	0.15	0.15	
Shock Limit (g)	10000	10000	10000	10000	10000	10000	

ELECTRICAL

Zero Acceleration Output (mV)	<±25	Differential
Excitation Voltage (Vdc)	2 to 10	
Input Resistance (Ω)	3500-4500	
Output Resistance (Ω)	3500-4500	
Insulation Resistance (MΩ)	>100	@100Vdc
Residual Noise (μV RMS)	<10	
Ground Isolation	Isolated from mounting surface	
Warm-up Time	<30 seconds	@10Vdc Excitation

ENVIRONMENTAL

Thermal Zero Shift (%FSO/°C)	±0.04	From 0 to +50°C
Thermal Sensitivity Shift (%/°C)	-0.20 ±0.05	From 0 to +50°C
Operating Temperature (°C)	-40 to +121	
Humidity	Epoxy Sealed, IP61	

PHYSICAL

Case Material	Anodized Aluminum, Black	
Cable	4x #32 AWG Leads, PFA Insulated, Braided Shield, Polyurethane Jacket	
Weight (grams)	1.0	Cable not included
Mounting	2x #0-80 x 1/4" Socket Head Cap Screws	

¹ Output is ratiometric to excitation voltage

Calibration supplied:	CS-FREQ-0100	NIST Traceable Amplitude Calibration from 20Hz to ±1/2dB Frequency Limit
Optional accessories:	MTG-E2 121 140A	Triaxial Mounting Block 3-Channel Precision Low Noise DC Amplifier Auto-Zero Inline Amplifier

MODEL 64C CRASH TEST ACCELEROMETER

TYPICAL FREQUENCY RESPONSE

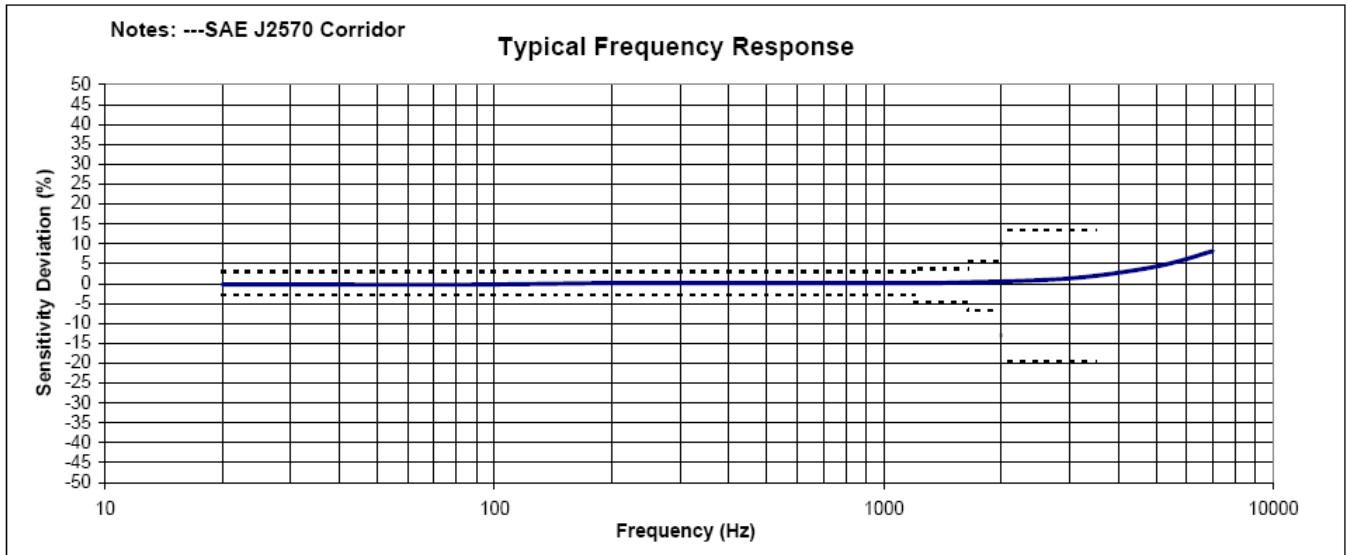

SCHEMATIC

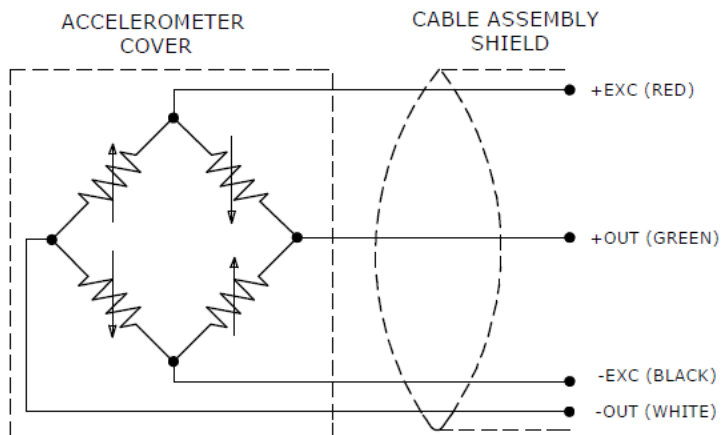

MODEL 64C CRASH TEST ACCELEROMETER

DIMENSIONS

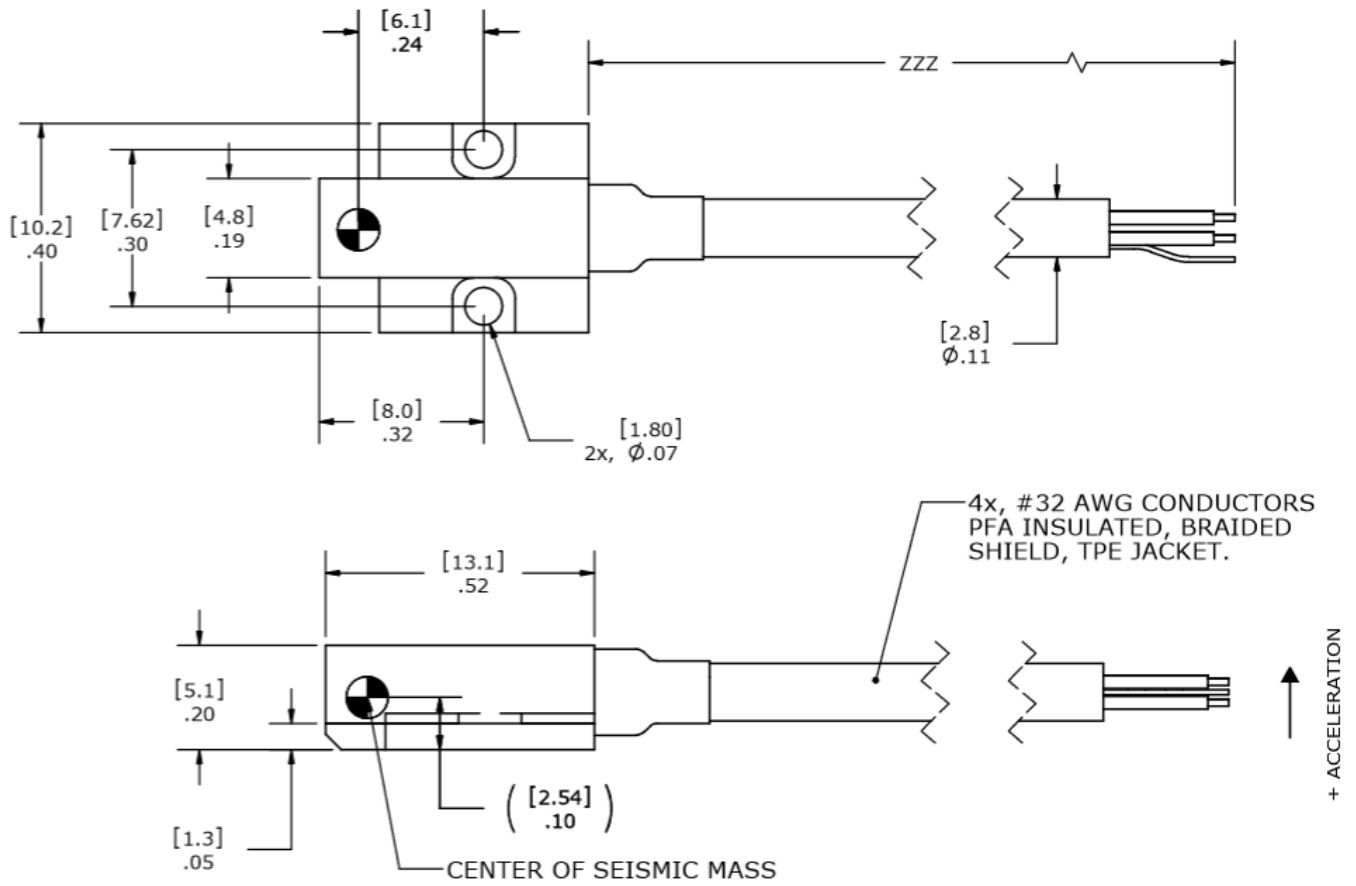

TRIAXIAL MOUNTING BLOCK

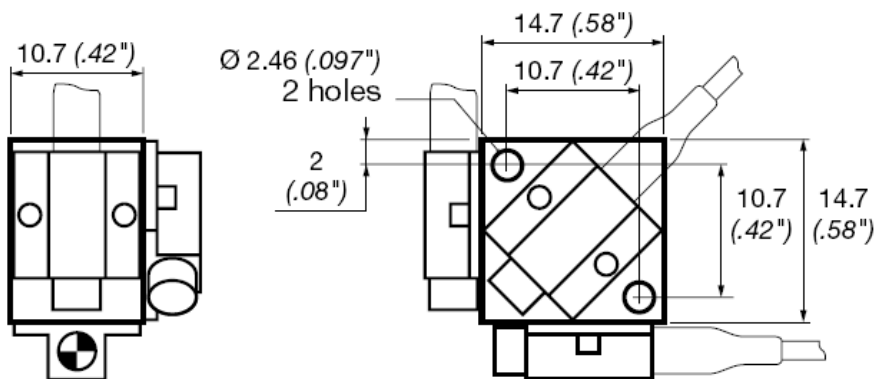

MODEL 64C CRASH TEST ACCELEROMETER

ORDERING INFORMATION

64C	GGGG	ZZZ	T	XXX
Range 0050 = 50g 0100 = 100g 0200 = 200g 0500 = 500g 2000 = 2000g 6000 = 6000g				
Cable length 240 = 240 inches, 20ft 300 = 300 inches, 25ft 360 = 360 inches, 30ft 197 = 197 inches, 5 meters 276 = 276 inches, 7 meters 394 = 394 inches, 10 meters				
Transverse Sensitivity Option Blank = <3% T = <1%				
Excitation Voltage Option Blank = 10Vdc 001 = 5Vdc 005 = 2Vdc				

Example;64C-2000-360
Model 64C, 2000g range, 360inch (30ft) cable length

Example;64C-0500-276T-001
Model 64C, 500g range, 276inch (7m) cable length, <1% transverse sensitivity option, 5V calibration