

Uncompensated SO-16 Pressure Sensor

SM9D, SM9G Series

FEATURES



- Uncompensated millivolt analog output
- Differential or gage pressure options
- Vertical or horizontal porting configurations
- Pressure ranges: 0.15, 0.6 & 1.5 PSI
- Variable supply voltage
- Built in ESD protection

DESCRIPTION

Silicon Microstructures provides its most popular pressure sensor die in a surface mount small outline package (SO-16) configuration. All parts in this series are uncompensated high performance die mounted in a rugged plastic package designed for surface mounting.

The low pressure SM9D/G series incorporates Silicon Microstructures' unique pressure die to achieve high performance in pressure ranges of 0.15, 0.6 & 1.5 PSI full-scale in gauge and differential configurations.

Industrial	Consumer	Medical
Handheld Meters	Sports Equipment	Hospital Beds
Pneumatic Gauges	Appliances	Wound Therapy
Pressure Switches		Health Monitoring

SM9G, SM9D Series

ABSOLUTE MAXIMUM RATING TABLE

All parameters are specified at $V_{DD} = 5.00$ V DC SUPPLY at 25°C, unless otherwise noted.

No.	Characteristic	Symbol	Minimum	Typical	Maximum	Units
1	Supply Voltage ^(a, c)	V_{DD}	-	-	6.5	V
2	Supply Current ^(a, c)	I_{VDD}	-	-	1.6	mA
3	Operating Temperature Range ^(b)	T_{OP}	-40	-	+85	°C
4	Storage Temperature ^(b)	T_{STG}	-40	-	+125	°C
5	ESD Voltage (HBM)	V_{ESD}	4	-	-	kV

NOTES:

a. The device can only be driven with the supply voltage connected to the pins as shown. The positive output will increase with increasing pressure applied to the package.

b. Tested on a sample basis.

c. Never exceed 6.5 V supply voltage under any operating conditions.

No.	Product Number	Operating Pressure	Proof Pressure (P_{PROOF}) ^(d, e)	Burst Pressure (P_{BURST}) ^(d, f)
6	SM9X-BXX-X-001S-000	0.15 PSI	1.5 PSI	3.0 PSI
8	SM9X-BXX-X-006S-000	0.6 PSI	4.8 PSI	6.0 PSI
9	SM9X-BXX-X-015S-000	1.5 PSI	12.0 PSI	15.0 PSI

NOTES:

d. Tested on a sample basis.

e. Proof pressure is defined as the maximum pressure to which the device can be taken and still perform within specifications after returning to the operating pressure range.

f. Burst pressure is the pressure at which the device suffers catastrophic failure resulting in pressure loss through the device.

OPERATING CHARACTERISTICS TABLE

All parameters are specified at $V_{DD} = 5.0$ V DC SUPPLY at 25°C, unless otherwise noted.

No.	Characteristic	Symbol	Minimum	Typical	Maximum	Units
10a	Span ^{(0.15 PSI) (g)}	V_{SPAN}	30	45	60	mV
10b	Span ^{(0.60, 1.5 PSI) (g)}		50	90	120	
11	Zero Offset	V_{ZERO}	-55	0	+55	mV
12	TC Span ^(g, i, j)	TCS	-0.24	-0.21	-0.15	%FS/°C
13	TC Zero Offset ^(g, i, j)	TCZ		0 to +100		μV/°C
14	TC Resistance ^(h, i, j)	TCR	0.17	0.20	0.23	%R _B /°C
15	Topside Linearity ^(g, j)	NL	-0.15	±0.1	0.15	%FS
16	Backside Linearity ^(g, j)		-0.35	±0.2	0.35	
17	Bridge Resistance	R _B	4.0	5.0	6.0	kΩ

Notes:

- g. Tested on a sample basis.
- h. The device can only be driven with the supply voltage connected to the pins as shown.
- i. Determined by measurements taken between -40°C and 85°C.
- j. Defined as best fit straight line.

Diagrams & Dimensions

Dual Horizontal Porting Configuration: SM9D-BB

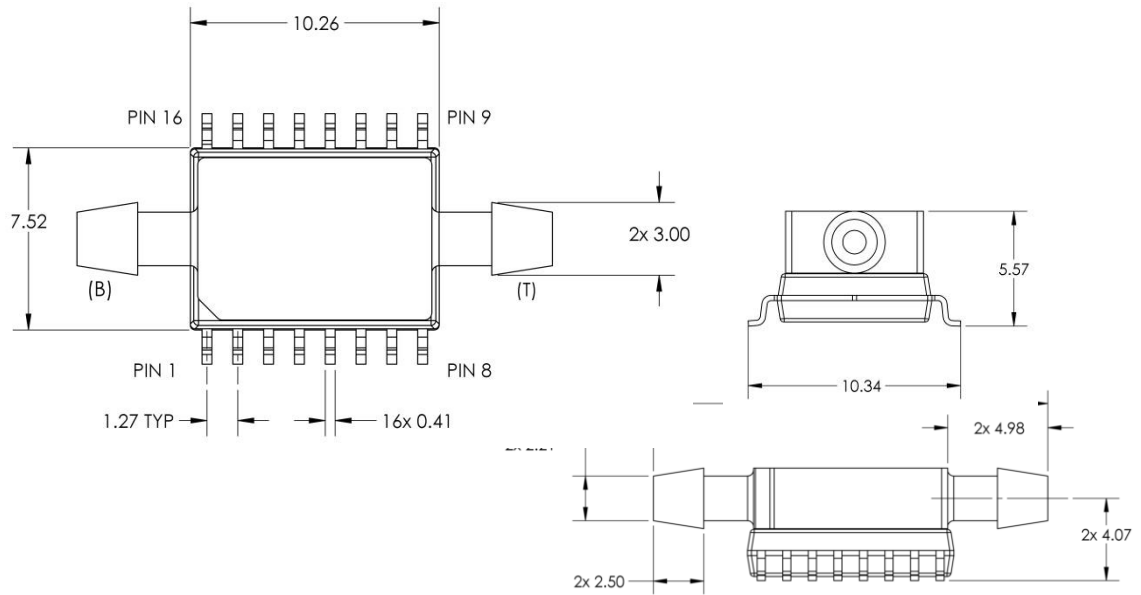

Dual Vertical Porting Configuration: SM9D-BC

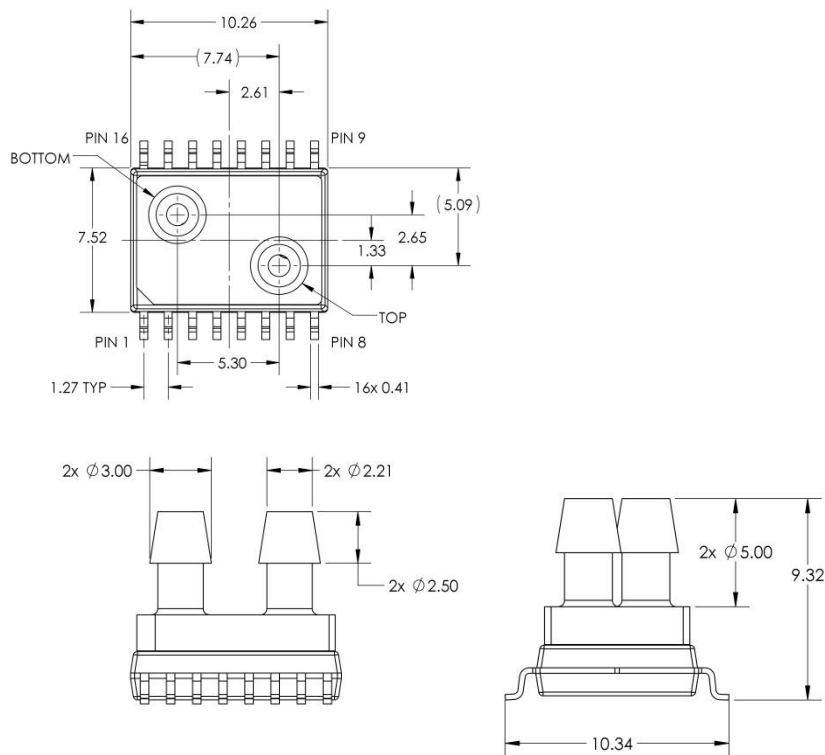

Notes:

- All dimensions in units of [mm]
- Moisture Sensitivity Level (MSL): Level 3
- Positive pressure applied to the topside of the die [T] is resulting in a positive change in output.

Single Vertical Porting Configuration: SM9G-BG

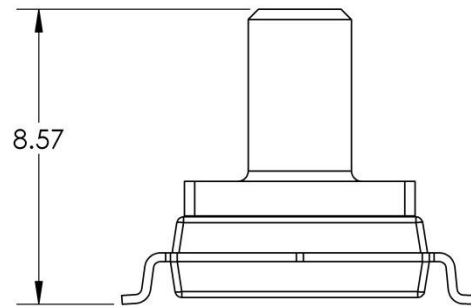
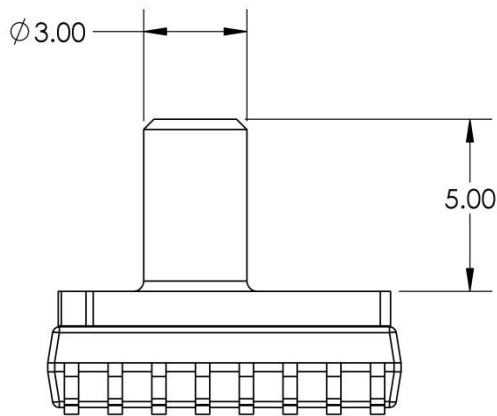
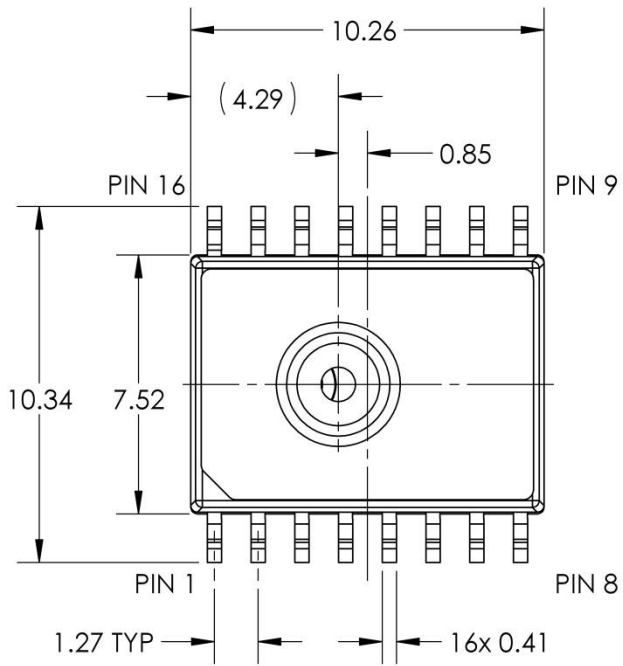

Notes:

- All dimensions in units of [mm].
- Moisture Sensitivity Level (MSL): Level 3
- Positive pressure applied to the port is resulting in a positive change in output. Pressure is applied to the backside of the die.

Part & Lot Number Identification

Top View

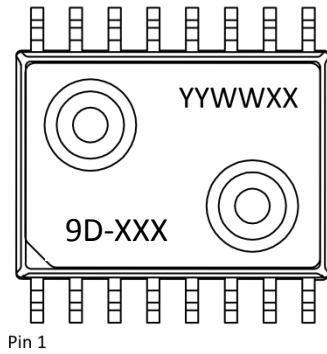

Pin 1

Bottom View

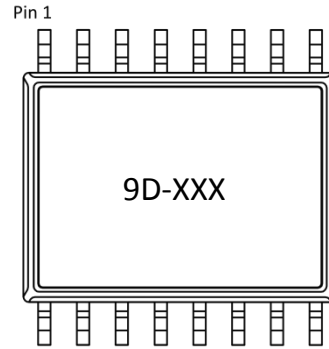

Pin 1

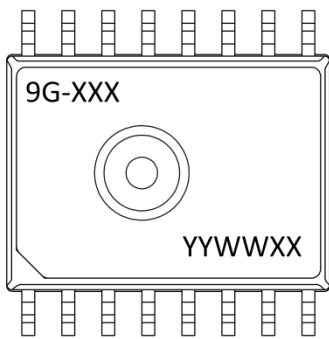

Pin 1

Only in Gage pressure

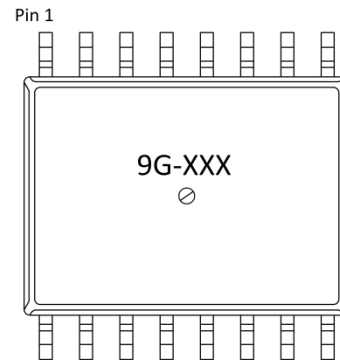

Pin 1

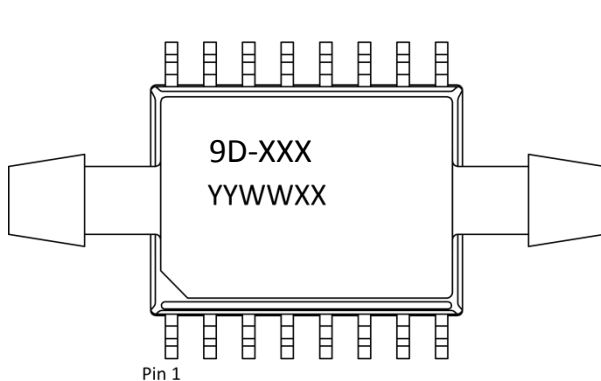

Pin 1

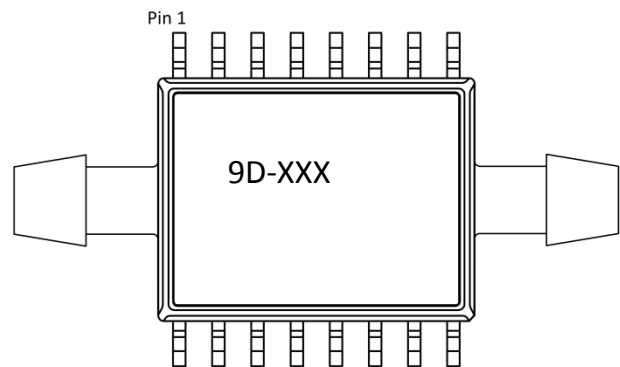

Pin 1

9G- = Gage, 9D- = Differential
 -001 = 0.15 PSI, -006 = 0.6 PSI, -015 = 1.5 PSI

SM9D Package Pin-Out (Dual Horizontal & Dual Vertical)

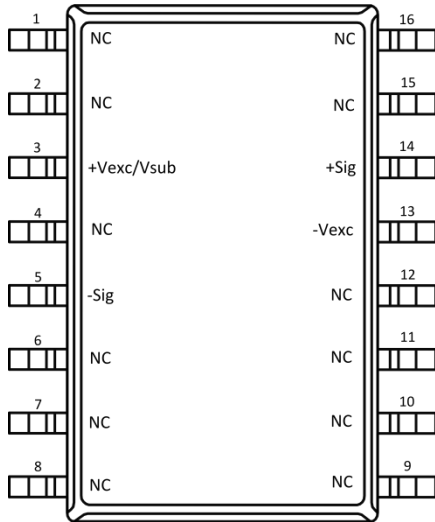

Typical Operation			
PIN	Description	Type	Value
3	+Vexc/Vsub	Power	Up to 5 V
5	-Sig	Analog Out	-
13	-Vexc	Power	Ground
14	+Sig	Analog Out	-

NOTES:

- Do not connect to NC pins
- Applies dual ported vertical and horizontal packages
- Positive pressure applied to the topside of the die [T] is resulting in a positive change in output.

SM9G Package Pin-Out (Single Vertical)

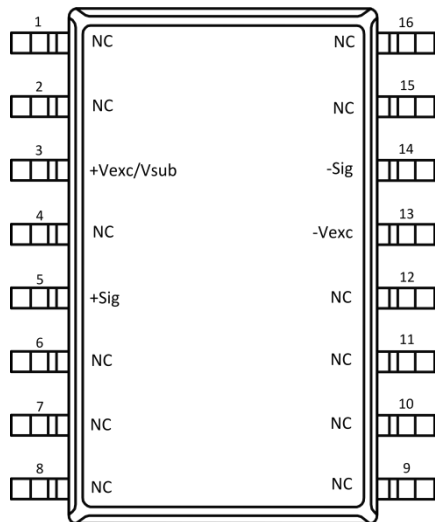

Typical Operation			
PIN	Description	Type	Value
3	+Vexc/Vsub	Power	Up to 5 V
5	+Sig	Analog Out	-
13	-Vexc	Power	Ground
14	-Sig	Analog Out	-

NOTES:

- Do not connect to NC pins
- Applies to single ported vertical package
- Positive pressure applied to the port results in a positive change in output. Pressure is applied to the backside of the die.

Ordering Information

Order Code	Pressure Type	Full-Scale Pressure Range	Cap Configuration	Shipping Configuration
SM9D-BCK-T-001S-000	Differential	0.15 PSI	Dual Vertical	Tape & Reel 350 devices per reel
SM9D-BCK-T-006S-000		0.60 PSI		
SM9D-BCK-T-015S-000		1.50 PSI		
SM9D-BBK-T-001S-000	Differential	0.15 PSI	Dual Horizontal	Tape & Reel 500 devices per reel
SM9D-BBK-T-006S-000		0.60 PSI		
SM9D-BBK-T-015S-000		1.50 PSI		
SM9G-BGK-T-001S-000	Gage	0.15 PSI	Single Vertical	Tape & Reel 400 devices per reel
SM9G-BGK-T-006S-000		0.60 PSI		
SM9G-BGK-T-015S-000		1.50 PSI		

Part Number Legend

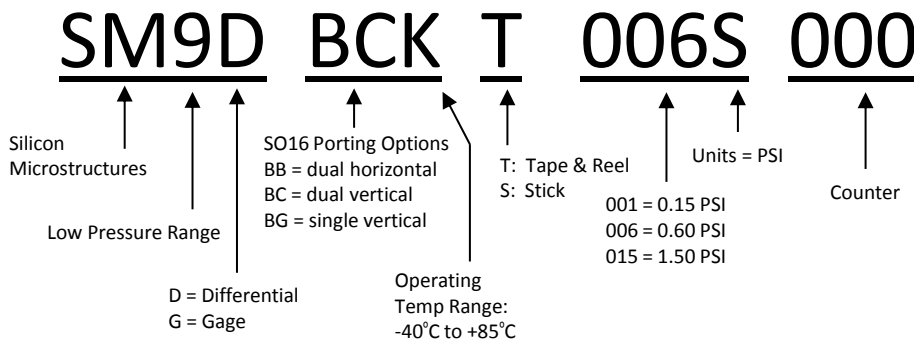

Qualification Standards

- REACH compliant
- RoHS compliant
- PFOS/PFOA compliant
- For qualification specifications please contact Sales



Silicon Microstructures Warranty and Disclaimer:

Silicon Microstructures, Inc. reserves the right to make changes without further notice to any products herein and to amend the contents of this data sheet at any time and at its sole discretion.

Information in this document is provided solely to enable software and system implementers to use Silicon Microstructures, Inc. products and/or services. No express or implied copyright licenses are granted hereunder to design or fabricate any silicon-based microstructures based on the information in this document.

Silicon Microstructures, Inc. makes no warranty, representation, or guarantee regarding the suitability of its products for any particular purpose, nor does Silicon Microstructures, Inc. assume any liability arising out of the application or use of any product or silicon-based microstructure, and specifically disclaims any and all liability, including without limitation consequential or incidental damages. "Typical" parameters which may be provided in Silicon Microstructure's data sheets and/or specifications can and do vary in different applications and actual performance may vary over time. All operating parameters, including "Typicals", must be validated for each customer application by customer's technical experts. Silicon Microstructures, Inc. does not convey any license under its patent rights nor the rights of others. Silicon Microstructures, Inc. makes no representation that the circuits are free of patent infringement. Silicon Microstructures, Inc. products are not designed, intended, or authorized for use as components in systems intended for surgical implant into the body, or other applications intended to support or sustain life, or for any other application in which the failure of the Silicon Microstructures, Inc. product could create a situation where personal injury or death may occur. Should Buyer purchase or use Silicon Microstructures, Inc. products for any such unintended or unauthorized application, Buyer shall indemnify and hold Silicon Microstructures, Inc. and its officers, employees, subsidiaries, affiliates, and distributors harmless against all claims, costs, damages, and expenses, and reasonable attorney fees arising out of, directly or indirectly, any claim of personal injury or death associated with such unintended or unauthorized use, even if such claim alleges that Silicon Microstructures, Inc. was negligent regarding the design or manufacture of the part.

Silicon Microstructures, Inc. warrants goods of its manufacture as being free of defective materials and faulty workmanship. Silicon Microstructures, Inc. standard product warranty applies unless agreed to otherwise by Silicon Microstructures, Inc. in writing; please refer to your order acknowledgement or contact Silicon Microstructures, Inc. directly for specific warranty details. If warranted goods are returned to Silicon Microstructures, Inc. during the period of coverage, Silicon Microstructures, Inc. will repair or replace, at its option, without charge those items it finds defective. The foregoing is buyer's sole remedy and is in lieu of all warranties, expressed or implied, including those of merchantability and fitness for a particular purpose. In no event shall Silicon Microstructures, Inc. be liable for consequential, special, or indirect damages.

While Silicon Microstructures, Inc. provides application assistance personally, through its literature and the Silicon Microstructures, Inc. website, it is up to the customer to determine the suitability of the product for its specific application. The information supplied by Silicon Microstructures, Inc. is believed to be accurate and reliable as of this printing. However, Silicon Microstructures, Inc. assumes no responsibility for its use. Silicon Microstructures, Inc. assumes no responsibility for any inaccuracies and/or errors in this publication and reserves the right to make changes without further notice to any products or specifications herein

Silicon Microstructures, Inc.™ and the Silicon Microstructures, Inc. logo are trademarks of Silicon Microstructures, Inc. All other service or product names are the property of their respective owners.

© Silicon Microstructures, Inc. 2001-2018. All rights reserved.