



ED34

Linear Encoder

SPECIFICATIONS

- High resolution
- High accuracy
- Contactless magnetic encoder for linear measurement
- In harsh environments
- Works with magnetic scale with 1mm pole pitch
- Small housing

Features

- Resolution: 5 μm
- Temperature range $-20^{\circ}\text{C} \dots +70^{\circ}\text{C}$
- Small Housing

Applications

- Linear or rotary displacement
- xyz-table
- Harsh environments

The ED34 is a linear incremental encoder based on the well established magneto resistive sensor technology. The contactless magnetic measuring principle is used for precise incremental displacement measurement by utilizing magnetized scales with 1mm pole pitch. Gap clearances up to 0.4mm are possible between scale and the read head. The encoder device is equipped with an internal sine / cosine interpolation unit which supports an A/B quadrature output with reliable position information. The small housing can be well integrated into machineries where position feedback is needed. The contactless AMR technology is well suited for applications in harsh environments where pollution like dust or oil which will not affect the measurement.

ABSOLUTE MAXIMUM RATINGS

Absolute maximum ratings are limiting values of permitted operation and should never be exceeded under the worst possible conditions either initially or consequently. If exceeded by even the smallest amount, instantaneous catastrophic failure can occur. And even if the device continues to operate satisfactorily, its life may be considerably shortened.

Parameter	Symbol	Conditions	Min.	Typ.	Max	Unit
Supply voltage	V _{cc}	Measured versus GND	-0.3		+5.5	V
Operating temperature	T _{op}		-20		+70	°C
Storage temperature	T _{storage}		-40		+85	°C

Stress above one or more of the limiting values may cause permanent damage to the device. Exposure to limiting values for extended periods may affect device reliability.

OPERATING CONDITIONS

If not otherwise noted, 25°C ambient temperature, 5V supply voltage applied.

Parameter	Symbol	Conditions	Min.	Typ.	Max	Unit
Supply voltage	V _{cc}	Measured versus GND	4.5	5	5.5	V
Supply Current	I		14	16	18	mA
Output Frequency ¹⁾	f _{out}			50		kHz
Resolution (flank to flank)	A			5		μm
Flanks per mm				200		
Ambient Temperature	T _{amb}		-20		+70	°C
Absolute accuracy	Δx		-10		+10	μm
Repeatability	R		-10		+10	μm
Deviation of pulse width	Δn		-	±10	±45	deg
Deviation of phase shift	Δφ		-	±10	±40	deg
Motions Speed	V		-	1 ²⁾	-	m/s
used magnetic pole width	p			1		mm
air gap sensor - scale	d		0.1		0.4	mm

1) Motion speed @ V = 1 m/s

2) Higher velocities possible on request

FUNCTIONAL DESCRIPTION

Typical performance graphs

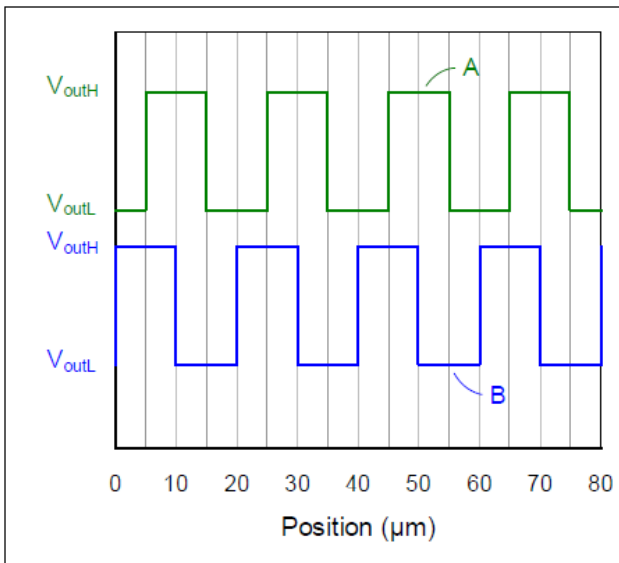

Fig.1: Typical output signals depends on direction of movement.

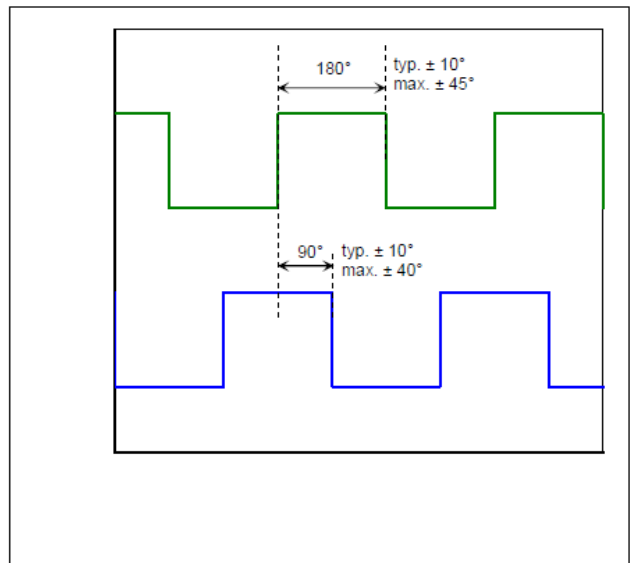
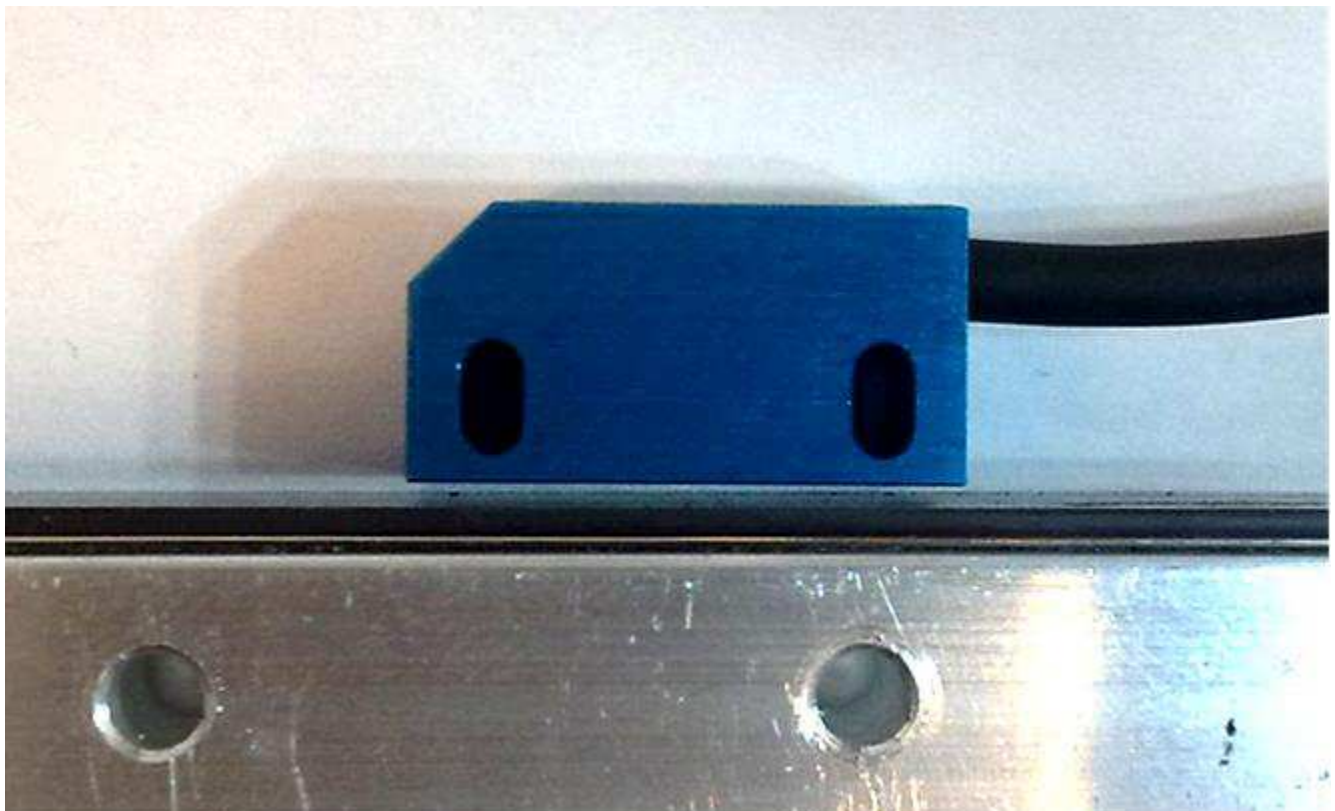

Fig.2: Pulse width deviation and phase shift.

MOUNTING OF ED34

The encoder works with a magnetic scale with 1mm pole pitch. The maximum gap clearance between scale and lower encoder surface is 0.4 mm.



TERMINALS

Connector: Binder Type: 09-9764-70-04

Pin	Name	Description	Color
1	A	Channel A	white
2	B	Channel B	yellow
3	Vcc	Supply 5V	green
4	Gnd	Ground	brown + shield

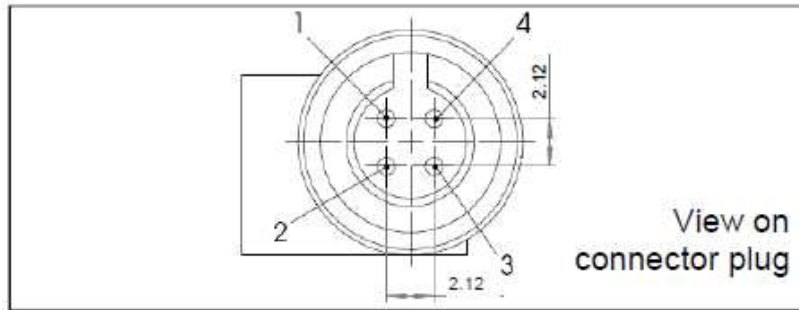

Connector: Binder Type: 09-9764-70-04

MECHANICAL DIMENSIONS

Scale 2:1

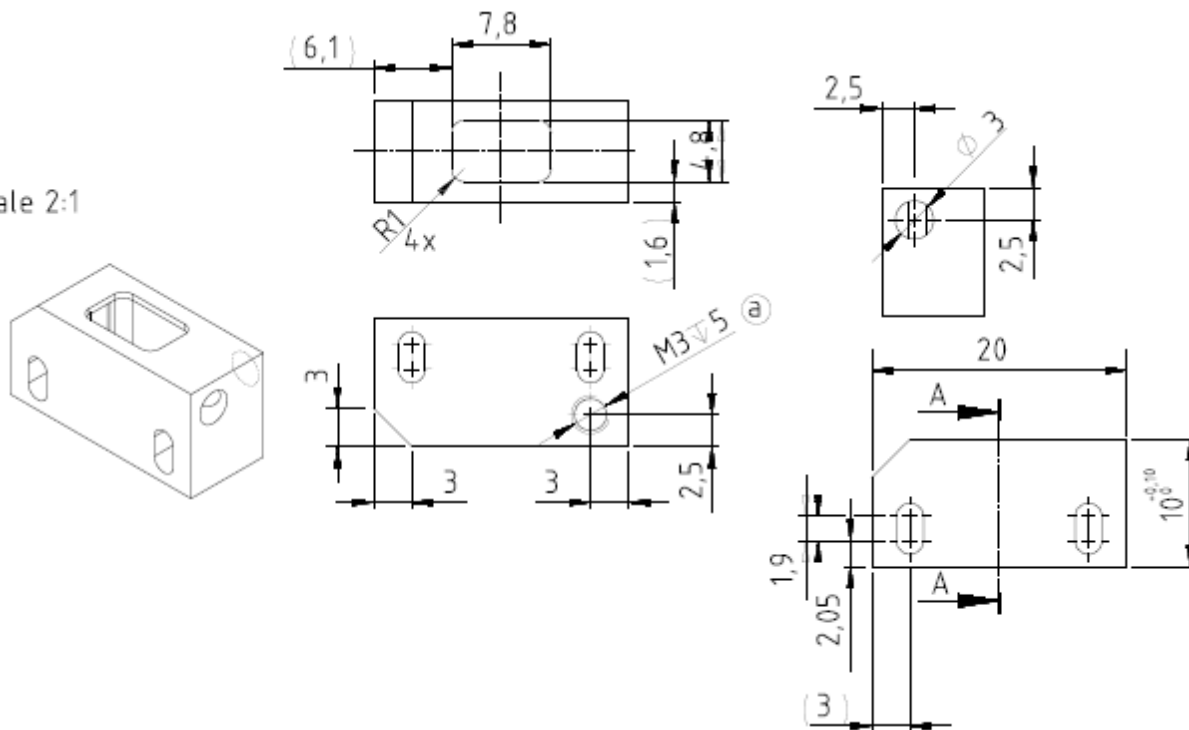

ORDERING CODES

Article Number **G-MRED-111**