

FEATURES

- ◆ Measures force & torque simultaneously
- ◆ Up to 6 components load cell
- ◆ Multiple and custom designs available
- ◆ Integrated amplifier optional
- ◆ Minimal Cross Effects

APPLICATIONS

- ◆ Mechanical linkage
- ◆ Structure testing
- ◆ Crash testing
- ◆ Automotive testing
- ◆ Industrial test benches

FN7325

Multi-axial Load Cell

SPECIFICATIONS

- ◆ **6-Components Load Cell**
- ◆ **Force range from 5 kN to 250 kN (1 klbf to 50 klbf)**
- ◆ **Measures force in three directions X, Y, Z**
- ◆ **Measures torque in three directions Mx, My, Mz**
- ◆ **Minimal Cross Effects**

The multi-axial **FN7325** measures force from 0-5 kN to 0-250 kN along three axes as well as the corresponding torque from 0-200 Nm to 0-7000 Nm. The **FN7325** is simple to use and install and in many diverse applications circumvents the necessity of employing multiple single-axes units.

The **FN7325** is a multi-axial sensors based on strain gages technology assembled in Wheatstone full bridges. Each sensor is able to measure up to 6 channels F_x , F_y , F_z , M_x , M_y & M_z which can be selected by customer, as example **FN7325-M6-ZLM** corresponds to a 3 channels (F_z , M_x & M_y) with a M6 sensor design.

Multiple designs and options can be adapted to this sensor such as integrated amplifier (**A1** or **A2**) or separated connectors or cable outputs. Its interfaces can also be modified to fit customer's specifications.

With many years of experience as a designer and manufacturer of sensors, TE CONNECTIVITY often works with customers to design or customize sensors for specific uses and testing environments.

On request, Instruction documents can be provided to ease the selection and use of our sensors and provide helpful tips.

STANDARD RANGES (FS)

| Model | FN7325-M6 | FN7325-M8 | FN7325-M10 | FN7325-M12 | FN7325-M16 |
|--|--------------|--------------|---------------|-----------------|---------------|
| Force X/Y in N [in lbf] | 5k [1k] | 15k [3k] | 30k [6k] | 60k [12k] | 100k [20k] |
| Force Z in N [in lbf] | 15k [3k] | 30k [6k] | 50k [10k] | 100k [20k] | 250k [50k] |
| Torque X/Y/Z in N.m [in lbf.ft] | 200 [145] | 600 [440] | 1.2k [885] | 2.8k [2 065] | 7k [5 160] |

PERFORMANCE SPECIFICATIONS (typical values at temperature 23±3°C)

| Parameters | |
|---------------------------------------|----------------------------------|
| Operating Temperature Range (OTR) | -20 to 80° C [-4 to 176° F] |
| Compensated Temperature Range (CTR) | 0 to 60° C (32 to 140° F) |
| Thermal Zero Shift in CTR | < 2% F.S. / 50° C [100° F] |
| Thermal Sensitivity Shift in CTR | < 2% of reading / 50° C [100° F] |
| Over-Range | |
| Without Damage | 1.2 x F.S. |
| Accuracy | |
| Combined non-linearity and hysteresis | ±1% F.S. |
| Cross effects | 3% F.S. (5% max.) |

Electrical Characteristics

| Model | FN7325 ¹ | FN7325-A1 | FN7325-A2 |
|--|-----------------------|--------------|-------------------------|
| Supply Voltage | 1 to 10 Vdc regulated | 10 to 30 Vdc | ±15 Vdc (±12 to ±18Vdc) |
| Sensitivity "FSO" per channel ⁶ | ±10 to 15 mV/V | ±2V ±0.2V | ±5 V ±0.25V |
| Zero Offset ⁶ | ±10mV | 2.5 V ±0.2V | 0 V ±0.25V |
| Insulation under 50Vdc | ≥100MΩ | | |

Notes

1. Sensors are calibrated with 10Vdc power supply as standard.
2. Standard electrical Termination: Connector output with mating plug included in delivery
3. Wiring schematic depends on the sensor and number of channels
4. Materials: Body in stainless steel cover in aluminium alloy
5. Protection index: IP50
6. Other signal output on request
7. CE conformance according to EN 61010-1, EN 50081-1, EN 50082-1

FN7325

Multiaxial Load Cell

DIMENSIONS (IN METRIC AND IMPERIAL)

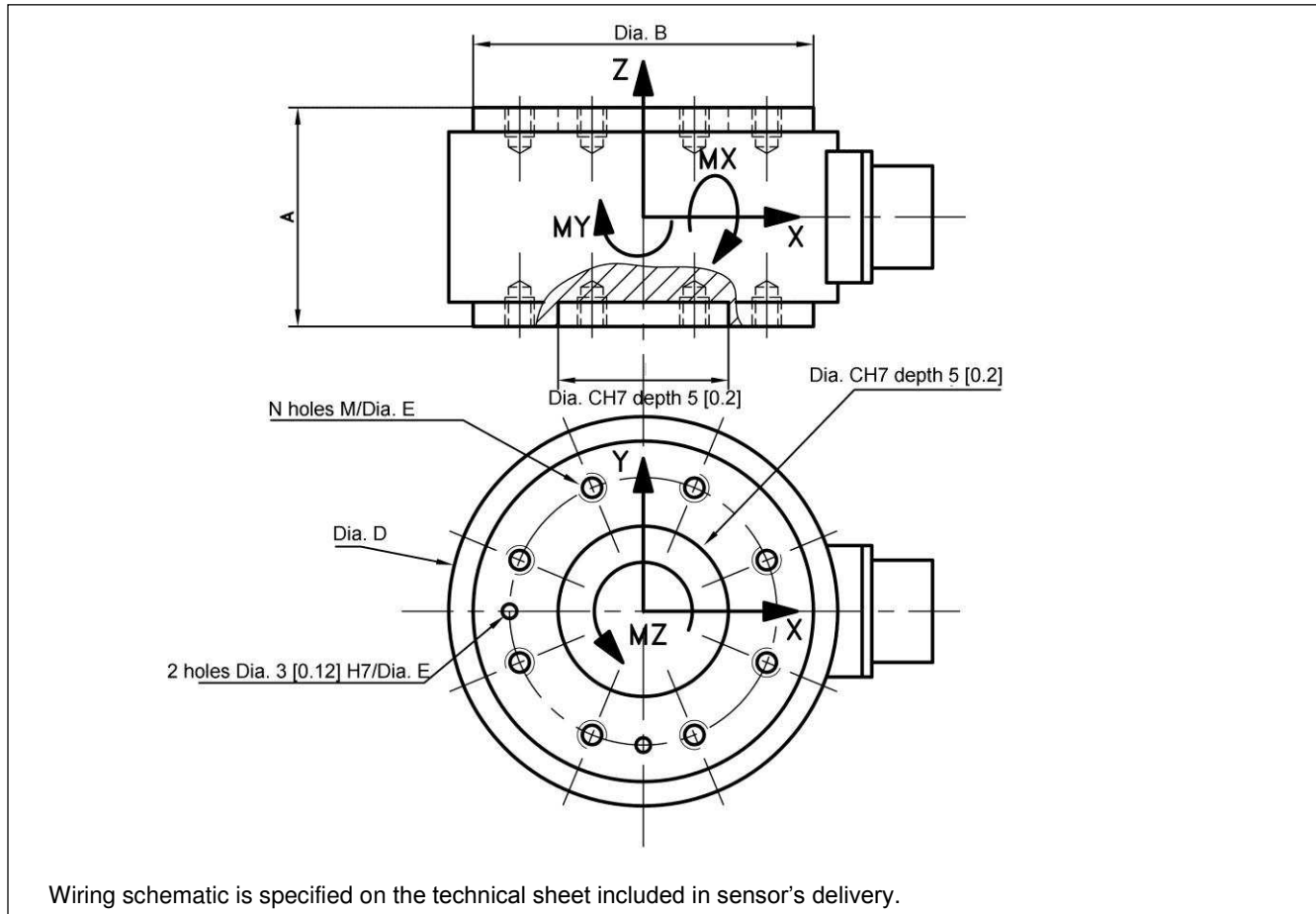

Dimensions in mm [inch]

| Model | FN7325-M6 | FN7325-M8 | FN7325-M10 | FN7325-M12 | FN7325-M16 |
|------------------------------------|----------------------|-----------------------|-----------------------|-------------------------|-------------------------|
| Force X/Y in N [in lbf] | 5k [1k] | 15k [3k] | 30k [6k] | 60k [12k] | 100k [20k] |
| Force Z in N [in lbf] | 15k [3k] | 30k [6k] | 50k [10k] | 100k [20k] | 250k [50k] |
| Torque X/Y/Z in N.m [in lbf.ft] | 200 [145] | 600 [440] | 1.2k [885] | 2.8k [2 065] | 7k [5 160] |
| A | 50 [1.97] | 55 [2.17] | 65 [2.56] | 75 [2.95] | 90 [3.54] |
| B | 70 [2.76] | 88 [3.46] | 114 [4.49] | 148 [5.83] | 190 [7.48] |
| C | 35 [1.38] | 40 [1.57] | 50 [1.97] | 65 [2.56] | 90 [3.54] |
| D | 80 [3.15] | 98 [3.86] | 124 [4.88] | 158 [6.22] | 200 [7.87] |
| N | 8 x M6/Ø55 [2.17] | 8 x M8/ Ø70 [2.76] | 8 x M10/Ø95 [3.74] | 12 x M12/Ø125 [4.92] | 12 x M16/Ø150 [5.91] |

FN7325

Multiaxial Load Cell

OPTIONS

A1 : Amplified Tension output with unipolar power supply

A2 : Amplified Tension output with bipolar power supply

V00 : Non-standard power supply calibration, replace "00" with value in Volt (standard 10Vdc, unamplified sensor only)

ORDERING INFO

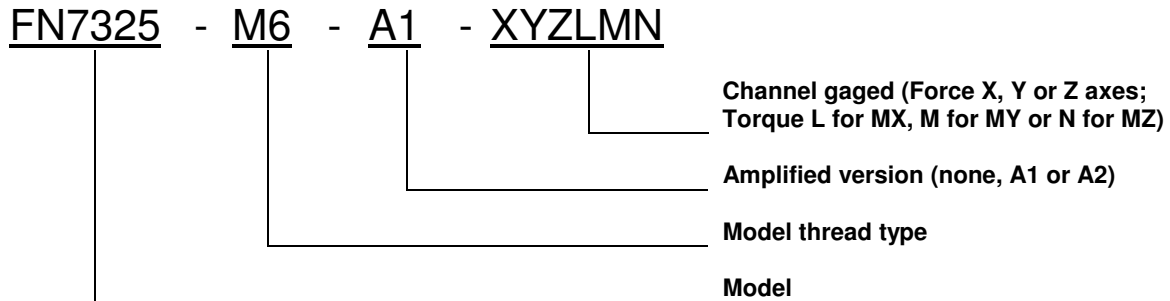

SUPPLIED ACCESSOIRES (CONNECTOR VERSION)

EFMX-12M: 12CTS mating plug Jaeger 530-502-006 with clamp 630-135-006 up to 3 axes XYZ or with A1 option

EFMX-27HD: 27CTS mating plug Jaeger 762-227-006 with clamp 769-227-006 above 3 axes XYZLMN or with A2 option