

FEATURES

- ◆ Compression only
- ◆ Accuracy regardless of force application point
- ◆ Extra flat and rugged design

APPLICATIONS

- ◆ On-board vehicle equipment
- ◆ Test bench equipment
- ◆ Laboratory and research

FN2570

Extra-flat Pedal Load Cell

SPECIFICATIONS

- ◆ Range 200 to 2500 N (40 to 500 lbf)
- ◆ Stainless Steel material
- ◆ Cable Output
- ◆ Very easy fixation

The **FN2570** load cell has been developed for pedal force testing. It attaches easily on all types of pedals and test rigs for endurance and fatigue tests, especially where size is an important factor.

The force is measured with high precision independent of the point of application of force. A strain relief spring strengthens the cable output.

A similar pedal load cells with a better accuracy 1%FS and integrated amplifier option exists as model **FN2114**.

With many years of experience as a designer and manufacturer of sensors, Measurement Specialties, Inc. often works with customers to design or customize sensors for specific uses and testing environments.

On request, Instruction documents can be provided to ease the selection and use of our sensors and provide helpful tips.

FN2570

Extra-flat Pedal Load Cell

STANDARD RANGES

Ranges in N (FS)	200	500	1000	1500	2000	2500
Ranges in lbf (FS)	40	100	200	300	400	500
Material	Aluminum	Stainless steel				

PERFORMANCE SPECIFICATIONS (typical values at temperature 23±3°C)

Parameters	
Operating Temperature Range (OTR)	-20 to 80° C [-4 to 176° F]
Compensated Temperature Range (CTR)	0 to 60° C [32 to 140° F]
Zero Shift in CTR	<0.5% F.S. / 50° C [/100° F]
Sensitivity Shift in CTR	<1% of reading / 50° C [/100° F]
Range (F.S.)	0-200 to 0-2500 N [0-40 to 0-500 lbf]
Over-Range	
Without Damage	1.5 x F.S.
Without Destruction	3 x F.S.
Accuracy	
Combined non-linearity & hysteresis	↑±2.5% F.S.

Electrical Characteristics

Model	FN2570
Supply Voltage	10Vdc
F.S. Output	±2mV/V
Zero Offset	±5% F.S.
Input Impedance/Consumption	700Ω
Output Impedance	700Ω
Insulation under 50Vdc	≥100MΩ

Notes

1. Electrical Termination: 2m shielded cable length
2. Protection Index: IP50 3.
3. CE conformance according to EN 61010-1, EN 50081-1, EN 50082-1

FN2570

Extra-flat Pedal Load Cell

DIMENSIONS & WIRING SCHEMATIC (IN METRIC AND IMPERIAL)

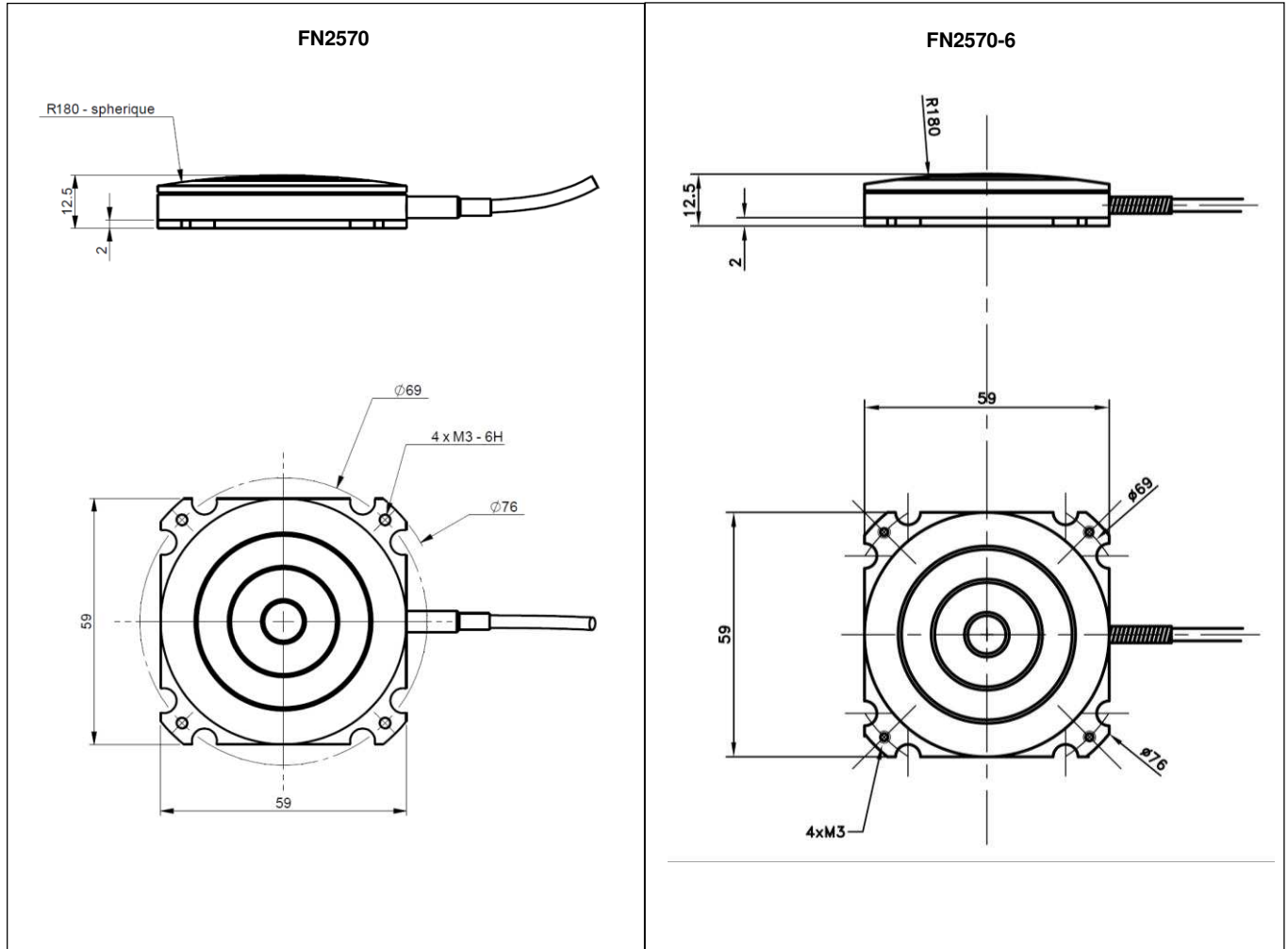

Wiring Schematic

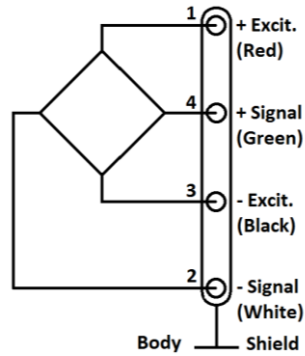

FN2570

Extra-flat Pedal Load Cell

OPTIONS

FN2570: Cable output with strait tube
FN2570-6: Cable output with spring
L00M : special cable length, replace "00" with total length in meters

ORDERING INFORMATION

FN2570-6	-	1KN	-	/L5M
Model	-	Range/Unit	-	Options
FN2570 FN2570-6	-	200N 500N 1KN 1.5KN 2KN 2.5KN	-	/L00M