

Digital Barometric Air Pressure (BAP) Sensor

SM1131-EEG-X-165-000 Barometric Air Pressure (BAP) Sensor

FEATURES

- Fully integrated pressure Sensor
- Measurement of absolute pressure: 60 - 165 kPa with over-range capability 40 - 180 kPa
- Full thermal compensation to accuracy ± 1.0 kPa
- Digital I²C data interface provides measurement, diagnostic, ID-data and controls:
 - pressure output, 16-bit resolution
 - temperature output (internal sensor), 16-bit res.
 - sensor diagnostics (state-of-health)
 - power-down control: Sleep Mode selected via I²C
 - unique device ID
- Two I²C slave addresses via pin coding
- Two 16-bit ADCs for acquisition of pressure and temperature inputs; pressure acquired at 20 kS/s
- Diagnosis of sensor, sensor supply wiring, and NVM check-sum supervision at power-on
- Sleep-mode with low current consumption
- Supply voltage 3.3 V or 5.0 V in the same device
- Large operating temperature range -40 to + 125°C

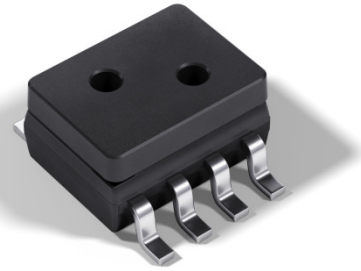

DESCRIPTION

The SM1131-EEG-X-165-000 is an absolute pressure sensor for barometric air pressure measurement (BAP). It includes a piezo-resistive pressure sensor die and a signal processing IC, which performs amplification and thermal compensation of the pressure sensor output to provide a linear, thermally stable signal output. The sensor delivers calibrated output data - pressure and temperature - with an I²C interface.

The calibration of this device corrects for pressure nonlinearity. Also the reading temperature from an on-chip temperature sensor can be read via I²C, as well diagnosis data. The component can be set to sleep-mode with very low consumption by a specific command. Wake-up from sleep-mode requires a toggling SCL input.

Sensor specific calibration data, configuration and product ID are stored in an embedded Non-volatile memory (NVM).

Medical	Industrial	Consumer
Negative Pressure Wound Therapy	Industrial Control	Sports Equipment
CPAP	Pneumatic Gauges	Appliances
Ventilators	Pressure Switches	
Gas Flow Instrumentation	Airflow Measurement	
Air Flow Monitors	Safety Cabinets	
	Gas Flow Instrumentation	

1. Absolute Maximum Ratings

Stresses beyond these absolute maximum ratings listed below may cause permanent damage to the device. These are stress ratings only; operation of the device at these or any other conditions beyond those listed in the operational sections of this document is not implied. Exposure to absolute maximum rated conditions for extended periods may affect device reliability. All voltages referred to VSS. Currents flowing into terminals are positive, those drawn out of a terminal are negative.

No.	Description	Condition	Symbol	Minimum	Maximum	Units
1	Supply Voltage		VDD	-0.3	6	V
2	Digital IO Voltage		V _{IO,DIG}	-0.3	VDD+0.3	V
3	Max. Digital IO Current (DC)		I _{IO,DIG}	-10	+10	mA
4	Ambient Pressure		p _A	1	600	kPa
5	Junction Temperature		T _J	-40	130	°C
6	Storage Temperature		T _{STG}	-40	125	°C
7	Power Dissipation	T _A ≤ 125°C	P _{el}		33	mW

2. ESD

No.	Description	Condition	Symbol	Min.	Typ.	Max.	Units
1	ESD HBM Protection at all Pins	AEC Q100-002 (HBM) chip level test	V _{ESD(HBM)}	-2		-2	kV
2	ESD CDM Protection at all Pins	AEC Q100-011 (CDM) chip level test	V _{ESD(CDM)}	-500		-500	V
3	ESD CDM Protection at Corner Pins	AEC Q100-011 (CDM) chip level test	V _{ESD(CDM), C}	-750		-750	V

3. Recommended Operating Conditions

The recommended operating conditions must not be exceeded in order to ensure proper functionality of the device. All parameters specified in the following sections refer to these recommended operating conditions unless stated otherwise.

No.	Description	Condition	Symbol	Min.	Typ.	Max.	Units
1	Supply Voltage		V_{VDD}	3.0	-	5.5	V
2	Low level input voltage at SDA, SCL		$V_{IN,I2C,lo}$	-0.3		0.9	V
3	High level input voltage at SDA, SCL		$V_{IN,I2C,hi}$	$0.8 * V_{VDD}$		$V_{VDD}+0.3$	V
4	Operating Pressure Range		p_A	40		180	kPa
5	Operating Temperature	ambient	T_A	-40		125	°C

4. External Components

No.	Description	Condition	Symbol	Min.	Typ.	Max.	Units
1	Supply bypass capacitor ^{*)}		C_{VDD}		100		nF

^{*)} Not tested in production

5. Electrical Characteristics

5.1 Global Sensor Parameters

No.	Description	Condition	Symbol	Min.	Typ.	Max.	Units
1	Accuracy pressure measurement, mid temperature range	$T_{MID} = 0 \dots 85^{\circ}C$, 60 ... 165Pa	ΔP_{TMID}	-1.0		+1.0	kPa
2	Accuracy pressure measurement, low temperature range	$T_{LOW} = -40^{\circ}C$, 60 ... 165kPa	ΔP_{TLOW}	-2.0		+2.0	kPa
3	Accuracy pressure measurement, high temperature range	$T_{HIGH} = 125^{\circ}C$, 60 ... 165kPa	ΔP_{THIGH}	-2.0		+2.0	kPa
4	Accuracy temperature measurement	$-40^{\circ}C \dots +125^{\circ}C$, referred to ambient T	ΔT	-5		+5	$^{\circ}C$
5	Power-up time	from supply VDD > 3.0V to output settled to 90% of final value	t_{UP}			5	ms
6	Step response time ^{*)}	pressure step response; output rising from 10% to 90% of final value	t_{RESP}			1	ms
7	Step response settling time ^{*)}	pressure step response; output settling to full accuracy	t_{SETTLE}			10	ms

^{*)} Not tested in production

5.2 Voltage Supply

No.	Description	Condition	Symbol	Min.	Typ.	Max.	Units
1	Current consumption	continuous operation	I_{VDD}	-	4.5	6.0	mA
2	Current consumption, sleep-mode ¹⁾	Sleep-mode, TEN open	$I_{VDD,SM}$		10	20	μA

¹⁾ Device set to sleep mode by digital control command.

5.3 I²C Interface

No.	Description	Condition	Symbol	Min.	Typ.	Max.	Units
1	SDA output low voltage	$I_{SDA} = 3 \text{ mA}$	$V_{SDA,OL}$	0		0.4	V
2	Low-to-High transition threshold	pins SA0, SCL	$V_{SDA,LH}$	0.5	0.6	0.7	VDD
3	High-to-Low transition threshold	pins SA0, SCL	$V_{SDA,HL}$	0.3	0.4	0.5	VDD
4	I ² C clock frequency		f_{SCL}	0		400	kHz
5	Bus free time between a START and STOP condition*)		t_{BUSF}	1300			ns
6	Clock low time*)		t_{LO}	1300			ns
7	Clock high time*)		t_{HI}	600			ns
8	START condition hold time*)		t_{SH}	100			ns
9	Data setup time*)		t_{SU}	100			ns
10	Data hold time*)		t_H	0			ns
11	Setup time for repeated START condition*)		t_{RSH}	600			ns
12	Setup time for STOP condition*)		t_{PSU}	600			ns
13	Rise time of SDA and SCL signals*)		t_R			300	ns
14	Fall time of SDA and SCL signals*)		t_F			300	ns
15	Capacitive load at bus lines		C_{Bus}			TBD	pF

*) Not tested in production

6. Functional Description

6.1 Overview

The SM1131-EEG-X-165-000 is a high precision, factory calibrated absolute pressure sensor for barometric air pressure (BAP) measurement. Pressure output data are available at a digital data interface (I²C).

Also temperature measurement data from an integrated temperature sensor and information on the sensor integrity are accessible via this digital interface.

6.2 Global Sensor Parameters

6.2.1 Digital Pressure Transfer Function

In general digital output data are available with a word length of 16 bit. The numeric representation is always as 2's complement, which results in a range of:

$$0 \dots +32767 \text{ counts (positive range, or } 0000h \dots 7FFFh) \\ -32768 \dots -1 \text{ counts (negative range, or } 8000h \dots FFFFh)$$

For representation of absolute pressure output only the positive range of values is used. In case of under pressure with pressure falling below the lower definition range, the MSB of the output data can be used as an under-range indicator (showing negative pressure data).

The pressure sensor device is calibrated in the end-of-line production test. The linear pressure transfer function is described by the following equation:

$$D_p = a_1 * P_A + a_0$$

Sensitivity a_1 and offset a_0 are trimmed during the calibration process to exhibit as low as possible sensitivity to external conditions (temperature).

6.2.2 P-range: 40 - 180 kPa

Pressure transfer function parameters, digital output:

Pressure		Digital Output		Sensitivity / Offset		
Symbol	Pressure [kPa]	Symbol	Value [counts]	Symbol	Value	Unit
$P_{A,1}$	40	$D_{p,1}$	0	a_1	220	counts/kPa
$P_{A,2}$	180	$D_{p,2}$	30800	a_0	-8800	counts

The positive number range is exploited for regular pressure output data up to the maximum +32767.

If the MSB of the 16-bit data word is 1, this indicates negative numbers, which can be used as an indicator for under pressure (pressure below minimum value $P_{A,1}$).

6.2.3 Pressure Accuracy

The accuracy of the measured pressure output is given in medium temperature range $T_{MID} = 0 \dots 85^{\circ}\text{C}$, low temperature range $T_{LOW} = -40^{\circ}\text{C} \dots 0^{\circ}\text{C}$, and high temperature range $T_{HIGH} = 85^{\circ}\text{C} \dots 125^{\circ}\text{C}$, respectively. Best accuracy is achieved in the medium temperature range.

The accuracy bands are widened linearly towards min. and max. temperatures as shown below:

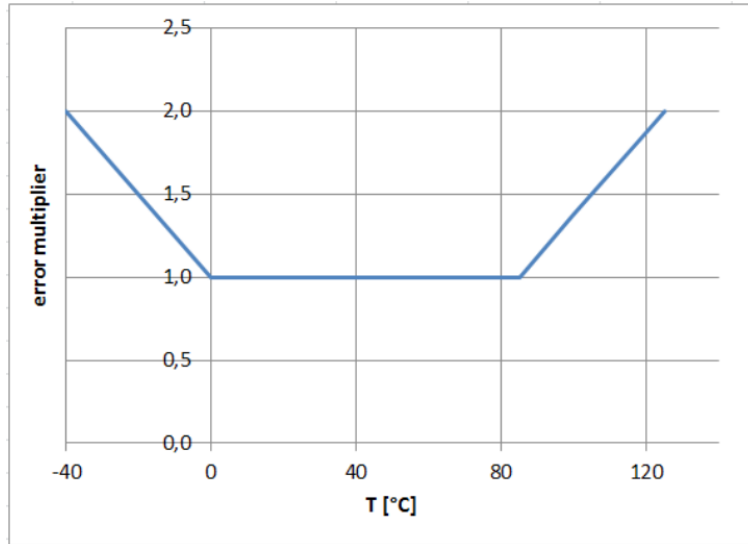

6.2.4 Digital Temperature Transfer Function

An internal temperature sensor measures the chip temperature. The temperature output which can be read via the digital interface is calibrated in Elmos' function test. The temperature characteristic is linear and is described by the following equation:

$$D_T = b_1 * T_A + b_0$$

Sensitivity b_1 and offset b_0 are trimmed during the end-of-line calibration.

Temperature transfer function parameters:

Temperature		Digital Output		Sensitivity / Offset		
Symbol	Pressure [kPa]	Symbol	Value [counts]	Symbol	Value	Unit
$T_{A,1}$	-50	$D_{T,OUT,1}$	0	b_1	150	counts/°C
$T_{A,2}$	150	$D_{T,OUT,2}$	30000	b_0	7500	counts

The positive number range are exploited up to the maximum +32767. When the MSB is 1, this indicates negative numbers and it can be used as an indicator for temperature below -50 °C (typical).

6.3 Voltage Supply

The sensor device is supplied from pin VDD (typical 5.0 or 3.3 V). From this supply input several internal voltage regulators are generating stabilized voltage levels for analog and digital circuit sections. The different internal voltages are monitored by power-OK comparator structures.

Also a stabilized voltage for the resistive pressure sensor cell is derived from VDD.

The digital data interface allows to set it into Sleep Mode using a specific command (Enter Sleep Mode), which ensures very low consumption $I_{VDD,SM}$. Of course, in Sleep Mode no pressure data are acquired.

For the I²C command to send the sensor into Sleep Mode see 6.6.2. To wake-up the sensor to normal operation, the clock input SCL shall be toggled (a rising edge at SCL will wake-up the device).

6.4 Diagnosis Functions

6.4.1 Sensor Bridge Diagnostics

Internal errors of the pressure sensor shall be detected and indicated at the signal output of the component.

Bridge Diagnostics

An integrated bridge diagnostic circuit supervises the resistive pressure sensor cell to detect any of the faults as follows:

- Sensor faults:
 - Short of any of the four bridge resistors of the pressure cell
 - Interruption of any of the four of bridge resistors
- Wiring faults:
 - Open connection of any of the bridge supply or signal inputs SVDD, SVSS, SIP, or SIN
 - Wrong connection of any sensor bridge terminal SIP or SIN to either SVDD or SVSS

For bridge diagnostics the signal input path pins SIP and SIN are pulled to ground with two matched low current sinks, which are active permanently (true background diagnostics). The voltage levels of the two signal path inputs (SIP and SIN) are monitored by two window comparators with detection thresholds of the low and high comparators at 25% SVDD and 75% SVDD, respectively.

The comparator outputs are combined in a logic (OR) and fed to a debouncing low pass filter. In case of an error the bridge check fail event is indicated by setting the bit bc_fail in the internal STATUS register.

Bridge Supply Diagnostics

Another comparator function checks if the supply to the sensor bridge is in its specified range. Here, in case of a supply error the bit bs_fail in the STATUS register will be set.

Error indication

The diagnosis bits bc_fail and bs_fail in the STATUS register (see 6.6) can be read via the digital I²C interface.

6.4.2 Configuration Memory Check

The integrity of data stored in the embedded NVM used as the configuration memory (calibration parameters, device configuration, device ID, etc.) is checked at power-up of the component by calculation of a check sum (CRC). If a check sum error is detected no reliable pressure calculation is possible.

Therefore, the sensor remains in idle state, i.e. no pressure data transferred to the output registers DSP_T and DSP_S. In this case the bits STATUS.dsp_s_up and dsp_t_up will never be set.

6.5 I²C Interface

The SM1131 features an I²C slave interface. This interface provides direct access to registers of the memory of the BAP sensor. An external I²C master (e.g. a microcontroller) can read from and write to memory addresses (registers) of the device using the following commands:

- **Random write:** Sets a memory address and writes data to consecutive memory addresses of the device starting at the set memory address.
- **Random read:** Sets a memory address and reads data from consecutive memory addresses of the device starting at the set memory address.
- **Read last:** Reads data from the device starting at the last memory address set by the master. This facilitates repeated reading of the same memory addresses without transmitting a memory address first.

All reads/writes must start at word aligned addresses (i.e. LSB of memory address equals 0) and read/write an even number of bytes.

I²C Interface Timing Diagram:

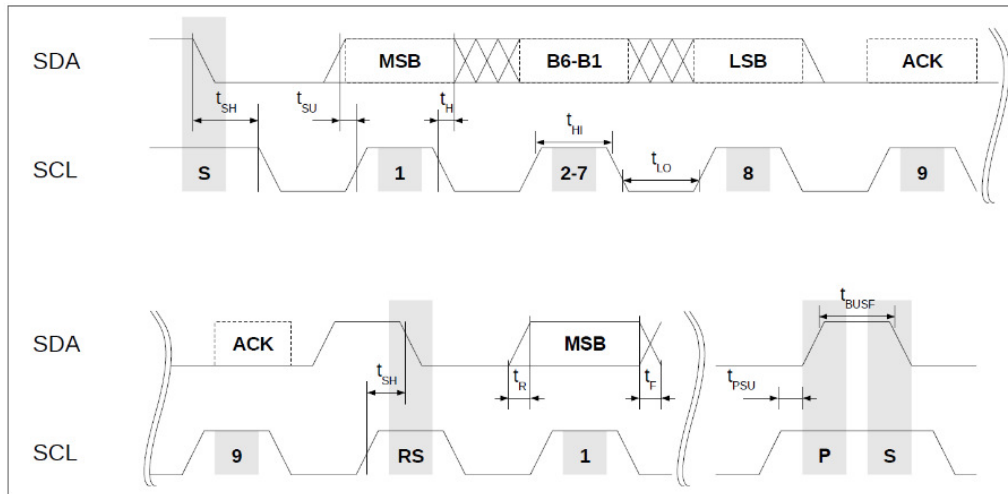

6.5.1 I²C Command Format

The BAP-Sensor SM1131 uses a standard 7-bit I²C slave address field. The LSB of the slave address specifies the frame type used to perform read and write operations.

For LSB = 0 the protocol is compatible to standard I²C EEPROMs, for LSB = 1 the protocol is extended by a CRC protection. Thus, each device occupies two I²C addresses: even addresses are for standard EEPROM compatible protocols and odd addresses are for CRC protected protocols. Unprotected and CRC protected frames can be interleaved.

The two different frame types - standard EEPROM (without CRC) or CRC protected - are shown in the next two figures.

I²C Read / Write Commands - Standard EEPROM compatible protocol:

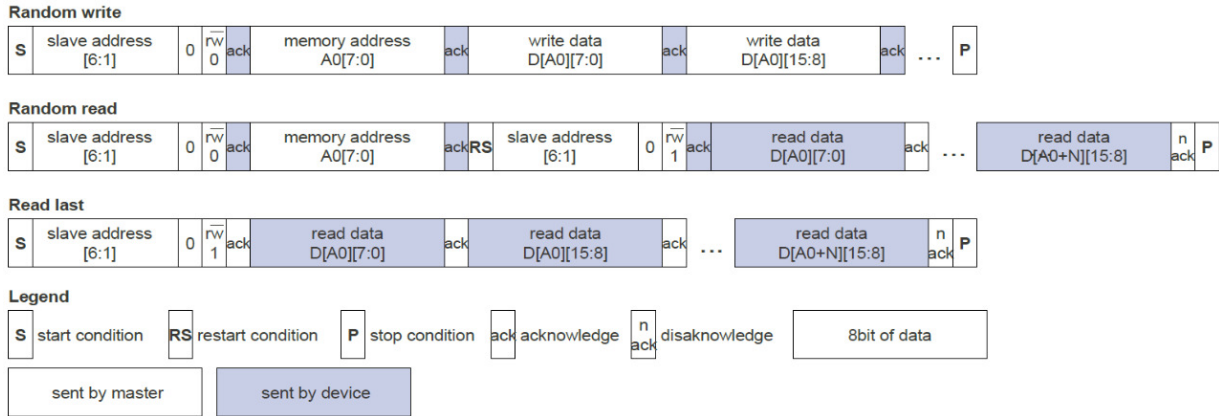

I²C Read / Write Commands - CRC protected protocol:

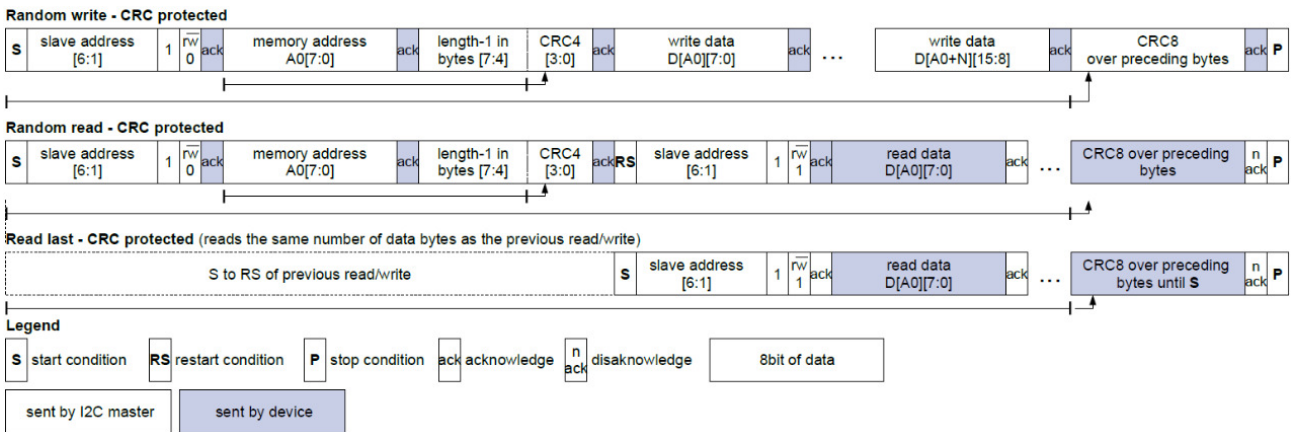

Two different slave addresses can be selected by use of pin-coding at SA0. This coding affects the LSB+1 of the slave address. Slave addresses as described in the next table are supported:

SA0 setting	7-bit slave address (EEPROM compatible)	7-bit slave address (CRC protected)
0	[b6:b0] = 1101100 (default)	[b6:b0] = 1101101 (default)
1	[b6:b0] = 1101110 (default)	[b6:b0] = 1101111 (default)

The memory address field sets the byte address of the first memory location to be read from or written to. Only 16-bit-word aligned reads/writes are supported, i.e. the LSB of memory address has to be zero always. The read/write data is transferred MSB first, low byte before high byte.

The length field (bits[7:4]) required for CRC protected frames specifies the number of data bytes to be transferred decremented by one, i.e. a value of 0001b corresponds to two bytes. All frames must transfer an even number of bytes. The maximum length for CRC protected read/write frames is 16/4 bytes. For unprotected frames the length is unlimited.

The CRC4 and CRC8 for redundancy check are computed in the same bit and byte order as the transmission over the bus. The polynomials employed are:

- CRC4: polynomial 0x03; initialization value: 0x0F
- CRC8: polynomial 0xD5; initialization value: 0xFF

If a CRC errors occurs, then the event bit `com_crc_error` in the STATUS register will be set.

6.5.2 I²C Command Examples

For all examples below the 7-bit device slave address used is 0x6C for unprotected commands, and 0x6D for CRC protected commands, respectively.

The command sequence following describes an unprotected Read command (without CRC) of 3 subsequent 16-bit words starting at memory address 0x2E to read the corrected IC temperature, corrected pressure signal, and (synchronized) status bits of the sensor.

Random Read:

Byte #	0	1	2	3	4	5	6	7	8
SBM (sent by master)	0xD8	0x2E	0xD9						
SBM comment	slave address 6C + LSB = 0 for Write	memory address	slave address 6C + LSB = 1 for Read						
SBS (sent by sensor)				0xF2	0x7D	0xEA	0x82	0x1E	0x00
SBS comment				DSP_T (Lo-Byte) ad. 0x2E	DSP_T (Hi-Byte)	DSP_S (Lo-Byte) ad. 0x30	DSP_S (Hi-Byte)	sync'ed Status (b7 - b0) ad. 0x32	sync'ed Status (b15 - b8)

The following sequence writes one 16-bit word to address 0x22. This will copy 0x6C32 into the command register CMD to move the component to Sleep Mode.

Random Write:

Byte #	0	1	2	3
SBM (sent by master)	0xD8	0x22	0x32	0x6C
SBM comment	slave address 6C + LSB = 0 for Write	memory address	Lo-Byte written to CMD[7:0]	Hi-Byte written to CMD[15:8]
SBS (sent by sensor)				
SBS comment				

The next command sequence describes a CRC protected Read command of 3 subsequent 16-bit words starting at memory address 0x2E.

Random Read - protected by CRC:

Byte #	0	1	2	3	4	5	6	7	8	9	10
SBM (sent by master)	0xDA	0x2E	0x5B	0xDB							
SBM comment	slave address 6D + LSB = 0 for Write	memory address	3: length = 4Byte B: CRC4	slave address 6D + LSB = 1 for Read							
SBS (sent by sensor)					0xF2	0x7D	0xEA	0x82	0x1E	0x00	0x65
SBS comment					DSP_T (Lo-Byte) ad. 0x2E	DSP_T (Hi-Byte)	DSP_S (Lo-Byte) ad. 0x30	DSP_S (Hi-Byte)	sync'ed Status (b7 - b0) ad. 0x32	sync'ed Status (b15 - b8)	CRC8 (calc'd)

The next example describes a Write of one 16-bit word (contents 0xCF9E) with CRC protection to address 0x36 to clear events in the STATUS register.

Random Write - protected with CRC:

Byte #	0	1	2	3	4	5
SBM (sent by master)	0xDA	0x36	0x16	0x9E	0xCF	0xA1
SBM comment	slave address 6D + LSB = 0 for Write	memory address	1: length = 2Byte 6: CRC4	STATUS (Lo-Byte) ad. 0x36	STATUS (Hi-Byte)	CRC8 (calculated)
SBS (sent by sensor)						
SBS comment						

6.6 Register Descriptions

Register Read or Write are performed via the digital communication interface. After power-up of the IC all registers except STATUS and CMD are write protected.

Command register:

0x22	CMD			
bits	name	default	rw	description
15:0	cmd	0	w	Writing to this register controls the state of the BAP device. 0x6C32: SLEEP Mode Initiate the power state SLEEP, powering down the ASIC 0xB169: RESET Performs a reset. After reset the power-up sequence will be executed, i.e. the registers are loaded with data from the configuration memory, also a CRC check is performed.

Temperature register:

0x2E	DSP_T			
bits	name	default	rw	description
15:0	dsp_t		r	Corrected temperature measurement value of the sensor. Whenever this register is updated with a new measurement the STATUS.dsp_t_up event bit is set.

Pressure register:

0x30	DSP_S			
bits	name	default	rw	description
15:0	dsp_s		r	corrected pressure measurement value of the sensor. Whenever this register is updated with a new measurement the STATUS.dsp_s_up event bit is set.

The registers DSP_T and DSP_S contain invalid data after power-up until the first temperature and pressure values have been measured by the device and transferred to these registers. In case a NVM CRC error occurred, the DSP_T and DSP_S registers would never be updated. **Thus, after power up it is necessary to wait until the STATUS.dsp_s_up and dsp_t_up bits have been set at least once before using the temperature or pressure data. It is not sufficient to wait just for a fixed time delay.**

Status register - synchronized:

0x32	STATUS_SYNC				
bits	name	default	rw	type	description
0	idle	0	rw	status	STATUS.idle
1	- reserved -	0	rw	event	reserved
2	- reserved -	0	rw	event	reserved
3	dsp_s_up	0	rw	event	when DSP_S is read STATUS.dsp_s_up is copied here
4	dsp_t_up	0	rw	event	when DSP_T is read STATUS.dsp_t_up is copied here
5	- reserved -	0	rw	status	reserved
6	- reserved -	0	rw	status	reserved
7	bs_fail	0	rw	event	STATUS.bs_fail
8	bc_fail	0	rw	event	STATUS.bc_fail
9	- reserved -	0	rw	event	reserved
10	dsp_sat	0	rw	status	STATUS.dsp_sat
11	com_crc_error	0	rw	event	STATUS.com_crc_error
12	- reserved -	0	rw	status	reserved
13	- reserved -	0	rw	status	reserved
14	dsp_s_missed	0	rw	event	STATUS.dsp_s_missed
15	dsp_t_missed	0	rw	event	STATUS.dsp_t_missed

The bits STATUS_SYNC[15:5,0] are identical to the bits STATUS[15:5,0].

The bits STATUS_SYNC[4:3] are copied from the STATUS register when the corresponding DSP registers are read. First reading the DSP registers and then STATUS_SYNC ensures that both values are consistent to each other.

The synchronized status STATUS_SYNC register can be used to continuously poll the pressure, temperature and status of the device with a single read command by reading three 16 bit words starting at address 0x2E. By evaluating STATUS_SYNC.dsp_t_up and STATUS_SYNC.dsp_s_up it can be determined if the values in DSP_T and DSP_S acquired during the same read contain recently updated temperature or pressure values.

Status register:

0x36	STATUS				
bits	name	default	rw	type ¹	description
0	idle	0	rw	status	0: chip in busy state 1: chip in idle state
1	- reserved -	0	rw	event	reserved
2	- reserved -	0	rw	event	reserved
3	dsp_s_up	0	rw	event	1: DSP_S register has been updated. Cleared when DSP_S is read
4	dsp_t_up	0	rw	event	1: DSP_T register has been updated. Cleared when DSP_T is read.
5	- reserved -	0	rw	status	reserved
6	- reserved -	0	rw	status	reserved
7	bs_fail	0	rw	event	1: bridge supply failure occurred
8	bc_fail	0	rw	event	1: sensor bridge check failure occurred
9	- reserved -	0	rw	event	reserved

0x36	STATUS				
bits	name	default	rw	type ¹	description
10	dsp_sat	0	rw	status	1: a DSP computation leading to the current DSP_T or DSP_S values was saturated to prevent overflow
11	com_crc_error	0	rw	event	1: communication CRC error
12	- reserved -	0	rw	status	reserved
13	- reserved -	0	rw	status	reserved
14	dsp_s_missed	0	rw	event	1: dsp_s_up was 1 when DSP_S updated
15	dsp_t_missed	0	rw	event	1: dsp_t_up was 1 when DSP_T updated

1)

- "Event" type flags remain set until cleared by writing '1' to the respective bit position in STATUS register (not STATUS_SYNC). Writing 0xFFFF to the STATUS register will clear all event bits.
- "Status" type flag represents a condition of a hardware module of the IC and persists until the condition has disappeared.

Serial Number register 0:

0x50	SER0			
bits	name	default	rw	description
15:0	ser0		r	Serial number of the IC, Lo-Word

Serial Number register 1:

0x50	SER1			
bits	name	default	rw	description
15:0	ser1		r	Serial number of the IC, Hi-Word

7. Package Reference

The SM1131-EEG-X-165-000 is available in a Pb free, RoHs compliant, 8-pin SO plastic package according to JEDEC MO-012-F, variant AA. The package is classified to Moisture Sensitivity Level 3 (MSL 3) according to JEDEC J-STD-020E with a soldering peak temperature of 260°C. **Note:** Thermal resistance junction to ambient $R_{th,ja}$ is 160 °C/W, based on JEDEC standard JESD-51.

Package Outline:

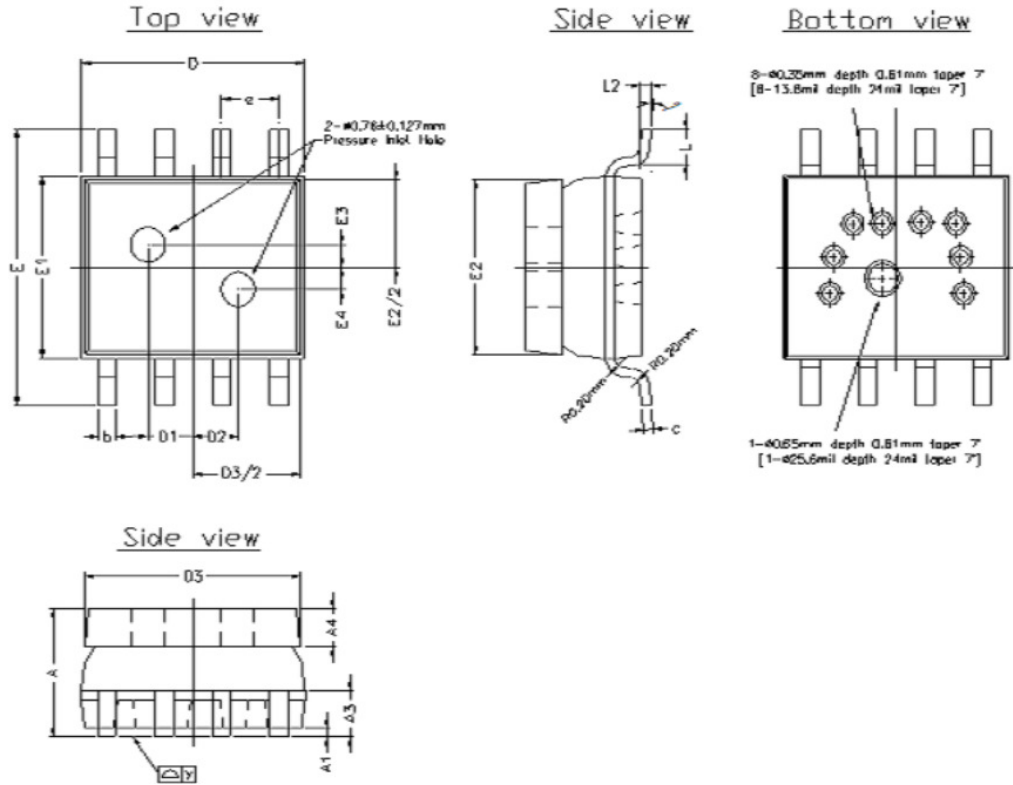

Note: Contact factory for specific location and type of pin 1 identification.

Package Characteristics:

Description	Symbol	Unit	Min.	Typ.	Max.
Package height	A	mm		2.79	
Stand off	A1	mm		0.19	
Width of terminal leads	b	mm		0.41	
Thickness of terminal leads	c	mm		0.20 Ref	
Length of terminal for soldering to substrate	L	mm		0.76	
Angle of lead mounting area	∅	°	0	-	8
Lead pitch	e	mm		1.27 BSC	
Package length	D	mm		4.95	
Package total width	E	mm		6.00	
Package body width	E1	mm		3.95	

Description	Symbol	Unit	Min.	Typ.	Max.
Thickness of the lid	A4	mm		0.83 Ref	
Length of lid	D3	mm		4.80	
Width of lid	E2	mm		3.80	
Off center position, longitudinal, inlet hole	D1 / D2	mm		1.00	
Off center position, lateral, inlet hole	E3 / E4	mm		0.49	

Ordering Information

Order Code	Minimum Pressure Range	Positive Pressure Range	Pressure Type	Supply Voltage	Port Configuration	Shipping Method
SM1131-EEG-S-165-000	0 kPa	165 kPa	Absolute	3.3 V	Dual Hole	Stick
SM1131-EEG-T-165-000						Tape & Reel
SM1131-EEG-S-165-001				5 V		Stick
SM1131-EEG-T-165-001						Tape & Reel

Part Number Legend

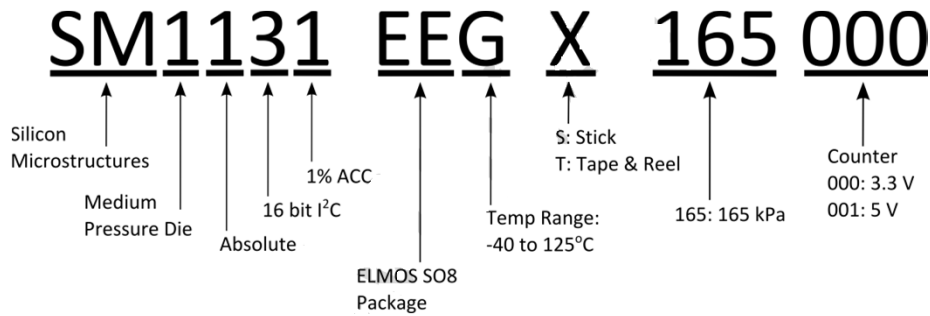

Silicon Microstructures Warranty and Disclaimer:

Silicon Microstructures, Inc. reserves the right to make changes without further notice to any products herein and to amend the contents of this data sheet at any time and at its sole discretion.

Information in this document is provided solely to enable software and system implementers to use Silicon Microstructures, Inc. products and/or services. No express or implied copyright licenses are granted hereunder to design or fabricate any silicon-based microstructures based on the information in this document.

Silicon Microstructures, Inc. makes no warranty, representation, or guarantee regarding the suitability of its products for any particular purpose, nor does Silicon Microstructures, Inc. assume any liability arising out of the application or use of any product or silicon-based microstructure, and specifically disclaims any and all liability, including without limitation consequential or incidental damages. "Typical" parameters which may be provided in Silicon Microstructure's data sheets and/or specifications can and do vary in different applications and actual performance may vary over time. All operating parameters, including "Typicals", must be validated for each customer application by customer's technical experts. Silicon Microstructures, Inc. does not convey any license under its patent rights nor the rights of others. Silicon Microstructures, Inc. makes no representation that the circuits are free of patent infringement. Silicon Microstructures, Inc. products are not designed, intended, or authorized for use as components in systems intended for surgical implant into the body, or other applications intended to support or sustain life, or for any other application in which the failure of the Silicon Microstructures, Inc. product could create a situation where personal injury or death may occur. Should Buyer purchase or use Silicon Microstructures, Inc. products for any such unintended or unauthorized application, Buyer shall indemnify and hold Silicon Microstructures, Inc. and its officers, employees, subsidiaries, affiliates, and distributors harmless against all claims, costs, damages, and expenses, and reasonable attorney fees arising out of, directly or indirectly, any claim of personal injury or death associated with such unintended or unauthorized use, even if such claim alleges that Silicon Microstructures, Inc. was negligent regarding the design or manufacture of the part.

Silicon Microstructures, Inc. warrants goods of its manufacture as being free of defective materials and faulty workmanship. Silicon Microstructures, Inc. standard product warranty applies unless agreed to otherwise by Silicon Microstructures, Inc. in writing; please refer to your order acknowledgement or contact Silicon Microstructures, Inc. directly for specific warranty details. If warranted goods are returned to Silicon Microstructures, Inc. during the period of coverage, Silicon Microstructures, Inc. will repair or replace, at its option, without charge those items it finds defective. The foregoing is buyer's sole remedy and is in lieu of all warranties, expressed or implied, including those of merchantability and fitness for a particular purpose. In no event shall Silicon Microstructures, Inc. be liable for consequential, special, or indirect damages.

While Silicon Microstructures, Inc. provides application assistance personally, through its literature and the Silicon Microstructures, Inc. website, it is up to the customer to determine the suitability of the product for its specific application. The information supplied by Silicon Microstructures, Inc. is believed to be accurate and reliable as of this printing. However, Silicon Microstructures, Inc. assumes no responsibility for its use. Silicon Microstructures, Inc. assumes no responsibility for any inaccuracies and/or errors in this publication and reserves the right to make changes without further notice to any products or specifications herein

Silicon Microstructures, Inc.™ and the Silicon Microstructures, Inc. logo are trademarks of Silicon Microstructures, Inc. All other service or product names are the property of their respective owners.

© Silicon Microstructures, Inc. 2001-2017. All rights reserved.