

TEI-19 Compensated

The TEI-19 compensated is a 19 mm small profile, media compatible, piezoresistive silicon pressure sensor packaged in a 316L stainless steel housing. It is designed for O-ring mounting and OEM applications where compatibility with corrosive media is required.

The sensing package utilizes silicone oil to transfer pressure from the 316L stainless steel diaphragm to the sensing element. A PCB is attached to the package that contains laser-trimmed resistors for temperature compensation and offset correction.

For a similar sensor with same outline dimensions and similar parameters, refer to the 154N Compensated pressure sensor.

Features

- O-Ring Mount
- -40°C to +125°C Operating Temperature
- Up to $\pm 0.1\%$ TYP. Pressure Non-Linearity
- Solid State Reliability
- Constant Current

Applications

- Medical Instruments
- Process Control
- Fresh & Waste Water Measurements
- Refrigeration/Compressors
- Pressure Transmitters
- Hydraulic Controls

Specifications

- **316L SS Pressure Sensor**
- **19mm Diameter Package**
- **0 - 100mV Output**
- **Absolute and Gage**
- **Temperature Compensated**

Standard ranges

Range	Psi G	Psi A
0 to 5	•	
0 to 15	•	•
0 to 30	•	•
0 to 50	•	•
0 to 75	•	•
0 to 100	•	•
0 to 150	•	•
0 to 300	•	•
0 to 500	•	•

TEI-19

Compensated

Performance specifications

Unless otherwise specified: Supply Current: 1.5mA, Ambient Temperature: 25°C

PARAMETERS		MIN	TYP	MAX	UNITS	NOTES
Span	Except 75 & 150 PSI	50	100	150	mV	
	75 & 150 PSI	75	-	225		
Zero Pressure Output	5 PSI	-2.0	0	+2.0	mV	1
	≥ 15 PSI	-1.0	0	+1.0	mV	1
Pressure Non-Linearity	Except 75 & 150 PSI	-0.2	±0.1	+0.2	%Span	2
	75 & 150 PSI	-0.3	±0.15	+0.3		
Pressure Hysteresis			5psi: -0.10 to 0.10 ≥15psi: -0.05 to 0.05		%Span	
Repeatability		-	±0.02	-	%Span	
Input Resistance		2.0	3.5	5.8	KΩ	
Output Resistance		3.8	-	6.0	KΩ	
Temperature Error – Span		-1.0	-	+1.0	%Span	3
Temperature Error – Offset		-1.0	-	+1.0	%Span	3
Thermal Hysteresis – Span		-0.25	±0.05	+0.25	%Span	3
Thermal Hysteresis – Offset		-0.25	±0.05	+0.25	%Span	3
Long Term Stability – Span		-	±0.25	-	%Span/Year	
Long Term Stability – Offset		-	±0.25	-	%Span/Year	
Supply Current		0.5	1.5	2.0	mA	4
Output Load Resistance		5	-	-	MΩ	5
Insulation Resistance (50VDC)		50	-	-	MΩ	6
Output Noise (10Hz to 1KHz)		-	1.0	-	μV p-p	
Response Time (10% to 90%)		-	0.1	-	ms	
Pressure Overload	Except 75 & 150 PSI	-	-	3x	Rated	7
	75 & 150 PSI	-	-	2x		
Pressure Burst	Except 75 & 150 PSI	-	-	4x	Rated	8
	75 & 150 PSI	-	-	2.6x		
Compensated Temperature	5 PSI	0	-	+50	°C	
	≥ 15 PSI	-10	-	+70	°C	
Operating Temperature	5 PSI	-20	-	+70	°C	9
	≥ 15 PSI	-40	-	+125	°C	9
Storage Temperature		-40	-	+125	°C	9

Media – Reference Port

LIQUIDS AND GASES COMPATIBLE WITH 316/316L ST STL

Notes:

1. Measured at vacuum for absolute (A), ambient pressure for gage (G).
2. Best fit straight line.
3. Over the compensated temperature range with respect to 25°C.
4. Guarantees output/input ratiometricity.
5. Load resistance to reduce measurement errors due to output loading.
6. Between case and sensing element.
7. The maximum pressure that can be applied without changing the transducer's performance or accuracy.
8. The maximum pressure that can be applied to a transducer without rupture of either the sensing element or transducer.
9. Maximum temperature range for product with standard cable and connector is -20°C to +105°C.
10. Standard gage units are not recommended for vacuum applications. For vacuum applications below 1/2 atmosphere, consult factory.
11. Device marking: each part shall be identified with model number, pressure range, type ("A" for absolute or "G" for gage), lot number, serial number and date code.
12. Shipping/package requirements:
The stainless-steel diaphragm is protected by a plastic cap. Each unit will be packaged individually in a plastic vial with anti-static foam.
13. Direct mechanical contact with diaphragm is prohibited. Diaphragm surface must remain free of defects (scratches, punctures, dents, fingerprints, etc) for device to operate properly. Caution is advised when handling parts with exposed diaphragms. Use protective cap whenever devices are not in use.

TEI-19

Compensated

Dimensions

(DIMENSIONS ARE IN INCHES [mm])

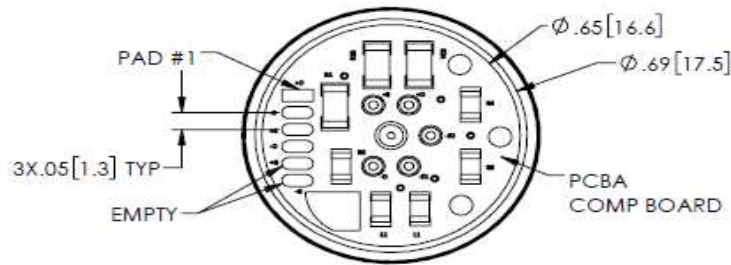
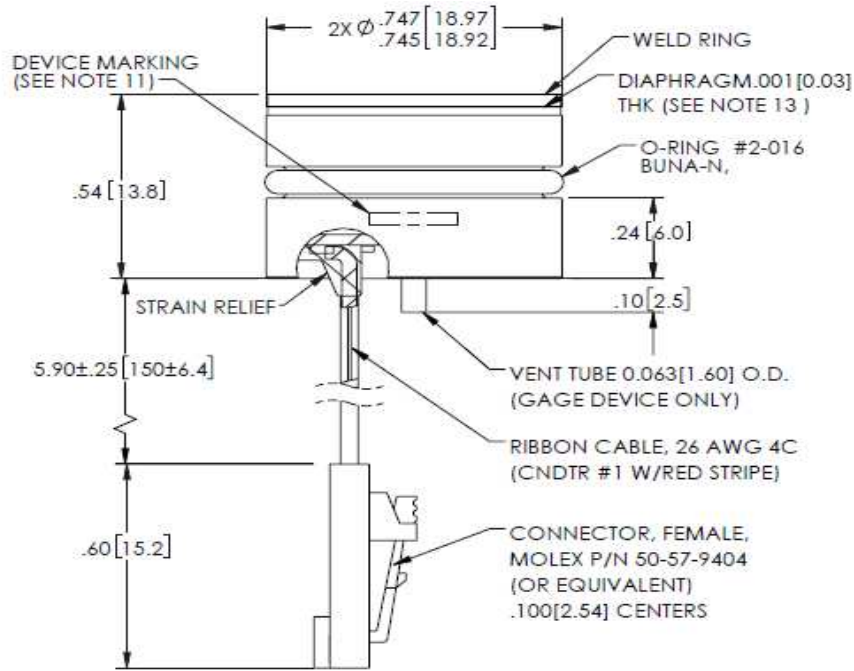

VIEW SHOWN W/O CABLE AND CONNECTOR FOR CLARITY

PAD NO	FUNCTION
1	+OUT
2	-EX
3	+EX
4	-OUT
5	GAIN FOR OPTION
6	OPTION

Equivalent schematic

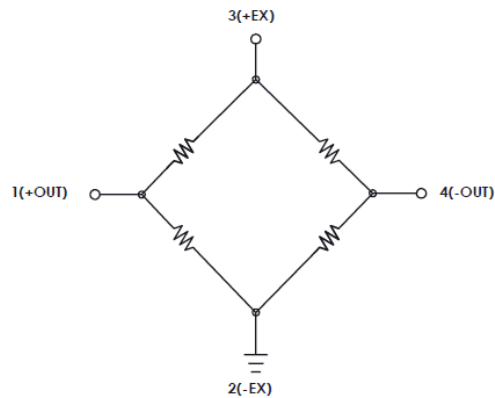

TEI-19

Compensated

Ordering information

