



FH/FC Series manual of Counter / Length

Thanks for select MYPIN products!
Pls carefully read this manual and fully understand its contents before operating this meter.

This manual is subject to change without prior notice

Warning

Please do not turn on the power supply until all of the wiring is completed.

Do not wire when the power is on.

Do not disassemble, repair or change the instrument.
Use this instrument within the scope of its specifications.

*Should be installed in a domestic environment.

* To avoid using this instrument in environment full of dust / caustic gas / strong vibration/ overflow water or explosive oil.

Application

- 1 Can be used as counter / length, counting meter / yard/angle / position, total count or batch count or current count
- 2 input: contact / proximity photoelectric switches / encoder, sine wave / Square wave / triangle wave etc voltage pulses
- 3 display : 4 / 6 / 8 digital LED duple row , range 0.0001-99999999
- 4 Multi-preset output: Relay\SSR\Buzz\4-20mA output etc.
- 5 power-down data saving for at least 10 years (EEPROM).
- 6 communication interface: RS485 RS232 LAN RJ45(MODBUS-RTU).

Panel(For Reference)

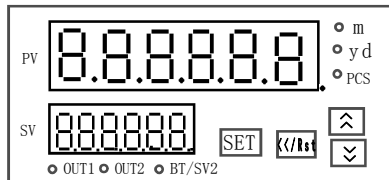

FH8 6 digit counter or length

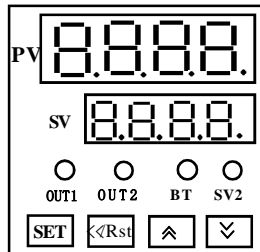

FH4 4 digit counter or length

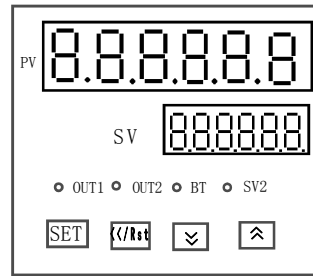

FH7 6 digit counter or length

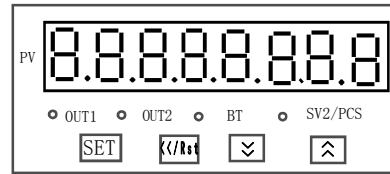

FH8 8 digit counter or length

PV window display :count data / parameter code

② SV window display : preset value / parameter value

- * **SET** Select or Confirm key
- * **RST** shift key / reset key
- * **▲** ADD / UP Key
- * **▼** SUB / Down Key
- * OUT1 OUT2 output LED, ON : active OFF : inactive
- * BT batch data LED, ON : batch data OFF: no batch data
- * SV2 preset point 2 LED ON: preset 2 OFF: no preset 2

Specifications

Power	90-260V AC 50/60Hz or 18-30V AC/DC, cmsp ≤ 5VA
input	sine, square, triangle wave pulse etc. 5V ≤ H ≤ 30V, 0 ≤ L ≤ 2V, up edge trigger Input impedance ≥ 20K Ω
speed	switch/pulse ≤ 5000CPS, encoder ≤ 2000CPS
range	4 digit 0-9999 6 digit 0-999999 8 digit 0-99999999
output	Relay: normal open 250VAC 3A/30VDC 3A resistive load SSR: DC 12V/24V 30mA, Triode: 60V/30mA
AUX.Power	DC 24V or /12V Max 40mA
comm	RS232, RS485 RJ45, MODBUS RTU protocol
Enviroment	temperature: 0-50°C humidity: 30-85%RH
Weight	< 350g

Ordering code

Model		Functions	
FH	□ □ - □ □ □ □ □ □ □ □ □ □	count/length	
Size	4	48W*48H*80L	
	6	48W*96H*80L	
	7	72W*72H*80L	
	8	96W*48H*80L	
	9	96W*96H*80L	
	10	160W*80H*70L	
power		90-260V AC/DC	
	E	18-30V OR 24VDC	
display	4	4 Dital LED	
	6	6 Dital LED	
	8	8 Dital LED	
function mode	C	counting	
	L	length/meter	
preset output	OUT1 F:BUZZ	N	none
		R	R: relay F:buzz
		S	triode/SSR
		I	I: 4-20mA V:0-10V
	OUT2	N	none
		R	R: relay F:buzz
		S	triode/SSR
			none
	OUT3	R	R: Relay F:buzz
		S	triode/SSR
			none
			none
communication	2	RS232	
	4	RS485	
	5	LAN RJ45	
AUX. power	A	12V/30mA	
	B	24V/30mA	
	D	other, E. g 5V/30mA	
		none	
Extensions	G	photoelectrical switch	
	S	proximity	
	R	encoder	
		none	
universal input:contact\switches\voltage pulse\encoder\ 90° phase difference, other input when ordering			

E.g: Model FH8E-6CRNB 6 dital LED counter,
size width 96*height48*length80mm, power supply 18-24V
DC, OUT1:relay, OUT2:none, comm:none, AUX. Power 24V/30mA
Model:FH7-6LRR4A-R100 6 digital counting length,
size width 72*height72*length80mm,Power supply:90-260V
AC/DC. OUT1:relay OUT2:relay, communication:RS85,
input:encoder 100pulse/Rpm, DC12V

Dimension and mounting

1 FH4	W 48 * H48 * L80mm
mounting	W45* H45mm
2 FH6	W48* H96* L80mm
mounting	W45* H92mm
3 FH7	W72* H72* L80mm
mounting	W68* H68mm
4 FH8	W96* H48* L80mm
mounting	W92* H45mm
5 FH9	W96* H96* L80mm
mounting	W92* H92mm
6 FH10	W160*H80* L70mm
mounting	W152*H76mm

Operation/parameter setting

1 Press **SET** key until to enter manu in setting menu,press **RST** key,LED flashing,press **RST** again to shift LED,press **▲** or **▼** key to modify data,press **SET** key to confirm ,then LED Stop to flash

Modify decimal point: when LED flashing, keeping hold **SET** key, and press **▲** key once, the decimal point will change once ,then loose key in required position

2 preset setting
Enter the setting menu, OR in dispaly estate, Pres **RST** key,LED flashing, then refer parameter setting steps to modify data

3 Preset point 1 and preset point 2 converting,
press **SET** key to convert SVwindow display SV2/BT LED:OFF display preset point 1, SV2/BT LED ON: dispaly preset point 2

4 FH8-8 8 digit counting data and preset convert,
Press **SET** key to convert SV window display PCS LED OFF: dispaly counting data
PCS LED ON: display preset,in this estate,
press **RST** key, LED flashing, then refer parameter setting steps to modify data

5 Reset Operation
Press **RST** key more than 2 seconds until PV LED display 0,then loose
or press terminal RST once to reset

Press **SET** key until to enter manu,then loose key,refer parameters setting steps to modify data

SET **Pc** Pc= vaule / Per Pulse ,range:0.0001-999999, PV display data= $\sum Pc*Pulse$, E.g Pc=10 PCS / Per pulse, Pc=0.01m/ per pulse ,Pc=1cm/per pulse, the count unit is determined by Pc parameter

SET **OUT1** preset point 1 : output control, can be select R C F N H L , refer to application

SET **2.01** / **10.00** preset point 1: output delay time (for only OUT1=R or C) range: 0.01-99.99 seconds

SET **5.12** / **200** preset point 2 setting (shield when unused) range:.0001-999999 required data: preset point 2 <= preset point 1

SET **OUT2** / **F** preset point 2 :output control, can be select R F H L (No C N) refer to application

SET **2.02** / **4.00** preset point :output delay time(for only OUT2=R) range: 0.01-99.99 seconds input select:

SET **INP** / **R** A/B : one input, contact / switches / pulse
C : two inputs: contact / switches / pulse
D encoder / wheel / 90 degree phase pulse

SET **dP** / **000.000** PV window count data decimal point:
int: 000000 1 decimal point : 00000.0
2 decimal point :0000.00 3 decimal point: 000.000 4 decimal point 00.0000

SET **CPS** / **5000** counting speed,
contact input:CPS=0020, switch input
CPS=1000, encoder input:CPS=5000

SET **DATA** / **no** power down saving
YES: saving data , start to count from power down data when power on
NO: no saving, start to count from 0 when power on

SET **NPN** / **PNP** NPN / PNP sensor select:
NPN: NPN or OC gate input
PNP: PNP or sine /square wave etc. voltae pulse input

SET **batch** / **50** preset batch (only for batch counter / length)
If analog output, E.g Bath=10000,output:4-20mA, PV: 0-10000 for 4-20mA, PV=5000 output 12mA

GOTO Bad Parameter

SET **bAd** / **9.6** communication baud rate ,
0: 9.6 KBit / s : 1:19.2K bit / S,
factory 0: 9.6 K Bit / s

SET **Addr** / **001** communication ID address :
000-255,factory=001

SET **LCK** / **000** Parameter lock, range : 0-255
LCK=000 open lock, can be read and write
LCK=010, lock, only read , cant write or modify

press **SET** to Return PC parameter or quit menu

Input application

contact input: should be connected capacitor to prevent contact jitter, capacity: 0.1-10uf, suggest capacitor : 4.7uf

1 A input application (Contact ,switch,encoder,voltage pulse)

INA :increase count ,connect between INA and 0V
INB : allow or forbid count, INA increase count when INB open or Low Level(<1V) , INA forbid or dont count when INB connect High level(H > 5V)

2 B input application:(Contact ,switch,encoder, voltage pulse)

INA: increase or decrease count, connect between INA and 0V
INB: used to control INA, INA increase count when INB OPEN or low Level(<1V), INA decrease count when INB connect High level (>5V)

3 C input application (Contact ,switch,encoder,voltage pulse),

PV data=INA-INB
INA :increase count,connect between INA and 0V
INB: decrease count,connect between INB and 0V

4 D input: encoder or 90 degree phase pulse

Reversible UP and Down counting with direction
INA :A phase increase count, connect between INA and 0V
INB: B phase decrease count, connect between INB and 0V
Changing A and B phase wiring position can change the counting UP OR Down

control output application

1 R control output:

preset value 1(SV1) > preset value 2(SV2)
PV : counting or length value

OUT1: if PV data >= SV1, OUT1 active, stop to count, after Delay time TIM1, reset PV data=0, reset OUT1 and OUT2 at the same time(OUT1 ,OUT2 =OFF)

OUT2: if PV data >= SV2, OUT2 active, but continue to count, after Delay time TIM2, reset OUT2 (OUT2=OFF)

2 C control output(only for SV1)

OUT1: if PV data >= SV1, OUT1 active and reset PV data=0 immediately, continue to count from 0, after Delay time TIM1, reset OUT1 and OUT2 at the same time(OUT1,OUT2=OFF)

3 F control output: totalize count

OUT1: if PV data >= SV1, OUT1 active, continue to count, OUT1 keeping active until manual reset

OUT2: if PV data >= SV2, OUT2 active, continue to count, OUT2 keeping active until reset by OUT1 R C control or manual reset, NOTICE :required SV2 < SV1

4 N control output: one cycle output(only for OUT1)

OUT1: if PV data >= SV1, OUT1 active, stop to count, OUT1 keeping active until manual reset

5 H High alarm control output

OUT1: if PV data >= SV1, OUT1 active, continue to count, if PV data < SV1, OUT1 Inactive, continue to count, OUT1 can be reset by manual

OUT2: if PV data >= SV2, OUT2 active, continue to count, if PV data < SV2, OUT2 Inactive, continue to count, OUT2 can be RESET by OUT1 R/C control output or manual reset

6 L LOW alarm control output

OUT1: if PV data < SV1, OUT1 active, continue to count, if PV data >= SV1, OUT1 Inactive, continue to count ,OUT1 can be reset by manual

OUT2: if PV data < SV2, OUT2 active, continue to count, if PV data >= SV2, OUT2 Inactive, continue to count, OUT2 can be RESET by OUT1 R/C control output or manual reset

Terminal connection(refer to the lable on meter)

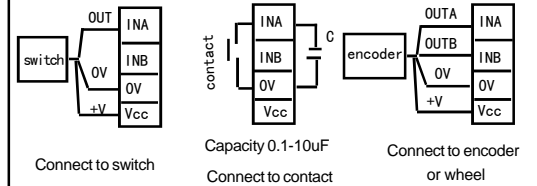
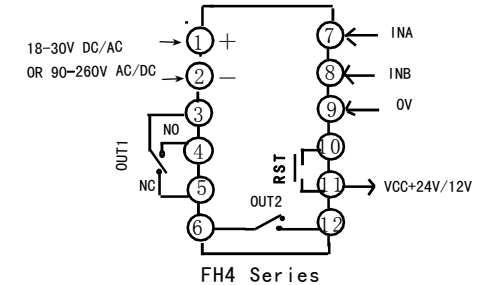
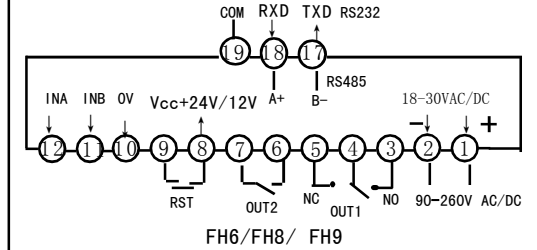
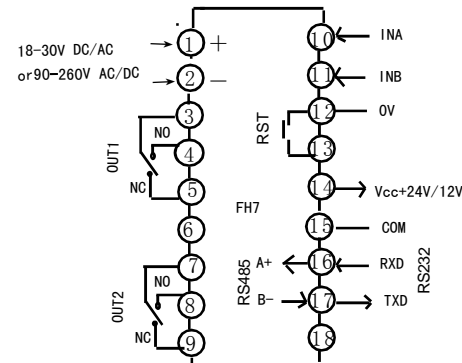

Factory Products Contains

- ★ 1 Copy of user manual
- ★ 1 Inspection certificate
- ★ 2 installing brackets.

We are responsible for the overall repairment for the failure of manufacturing quality within 12 months since the date of purchase.

Repair fee will be charged accordingly for damage caused by improper use.

Modbus protocol or other information

PLS Download from :www.mypinchina.com
IP/wechat: 86-18689341985
Email:sale@mypinchina.com

Main Products

- weight indicator /controller
- Counter & length meter
- Temperature controller
- Time relay
- Ampere & Voltage meter
- Power meter
- Frequency / Tacho / Line-speed meter
- Universal Sensor indicator
- Transmitter
- Proximity sensor Photo-electrical sensor