

DALI Dimmable driver - constant voltage Series 45W



■ Features:

- Output constant Current
- Range 100-265VAC
- Built-in active PFC function
- Efficiency up to 85%
- Protections:short circuit/over load/ over circuit/over temperature
- Cooling by free air convection
- IP20 design for indoor installation.
- Dimming function: Built in DALI interface dimming function conform to DALI Protocol IEC62386
- Dimming range from 0.1% to 100%
- Suitable for intelligent LED lighting
- Compliance to worldwide safety regulations for lighting
- Suitable for dry locations

■ Specification



Model		KV-12045-DA	KV-24045-DA
Output	DC Voltage	12V	24V
	Voltage Tolerance	±0.5V	
	Rated current	0 - 3.75A	0 -1.88A
	Rated power	45W	45W
Input	Voltage Range	100-265VAC	
	Frequency Range	47 - 63HZ	
	Power Factor	PF≥0.98/120VAC PF≥0.95/230VAC PF≥0.95/265VAC (Full loading)	
	Full Load Efficiency(Typ.)	81%	85%
	AC Current(Max.)	0.49A	0.47A
	Leakage current	<0.5mA	
Protection	Short Circuit	Protection type: Hiccup mode, recovers automatically after fault condition is removed.	
	Over Load	≤120%	
	Over Circuit	≤1.2*Iout	
	Protection Class:	II	
	Over temperature	100°C±10°C shut down o/p voltage, re-power on to recover	
Environment	Working TEMP.	-40 - +60°C	
	Working Humidity	20 - 90%RH,non-condensing	
	Storage TEM.,Humidity	-40 - +80°C, 10 - 95%RH	
	TEMP.coefficient	±0.03%/°C (0 - 50°C)	
	Vibration	10 - 500Hz, 2G 12min./1 cycle, period for 72min.each along X,Y,Z axes.	
Safety & EMC	Safety standards	EN61347-1 EN61347-2-13 IP20	
	Withstand voltage	I/P-O/P:3.75KVAC I/P-FG:1.88KVAC O/P-FG:0.5KVAC	
	Isolation resistance	I/P-O/P I/P-FG O/P-FG: 100MΩ/500VDC/25°C/70%RH	
	EMC Emission	EN55015,EN61000-3-2 (≥60%load)	
	EMC Immunity	EN61000-4-2,3,4,5,6 ,11,EN61547,A light industry level (surge4KV)	

DALI Dimmable driver - constant voltage Series 45W

Others	Weight	0.45Kg
	Dimension	180*60*35mm (L*W*H)
	packing	355*215*215mm/20pcs/CTN
Notes	1. All parameters NOT specially mentioned are measured at 230VAC input , rated load and 25°C of ambient temperature. 2. Tolerance: includes set up tolerance, line regulation and load regulation . 3. The power supply is considered as a component that will be operated in combination with final Equipment. Since EMC performance will be affected by the complete installation, the final equipment manufactures must be-qualify EMC Directive on the complete installation again.	

■ Mechanical Specification

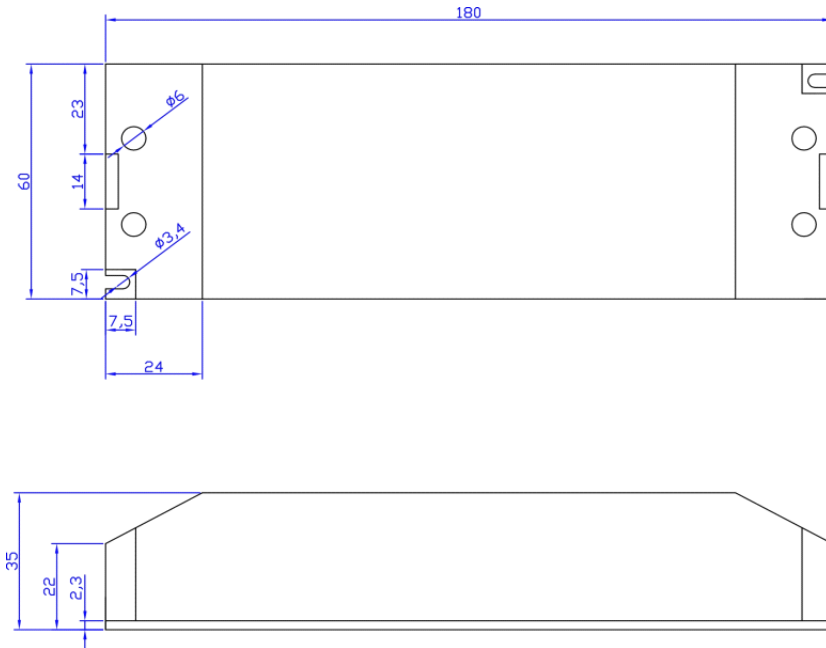

■ Label



- ※Input with Live Wire(L) Neutral Wire (N)
- ※Output LED SEC output Positive(LED+),output negative(LED-).Connected to LED Lamps.
- ※Signal Dimming DA1, DA2 (No polar) connected to the BUS of the DALI Master.
- ※Suggested wire diameter: Input 0.75-4mm²; Output: 0.5-2.5mm²
- ※Please make sure you connect these correctly otherwise your product will not function correctly and could be damaged.
- ※Note: Any other requests we can customized.

DALI Dimmable driver - constant voltage Series 45W

■ Dimming Operation

Operation Reference No.1:

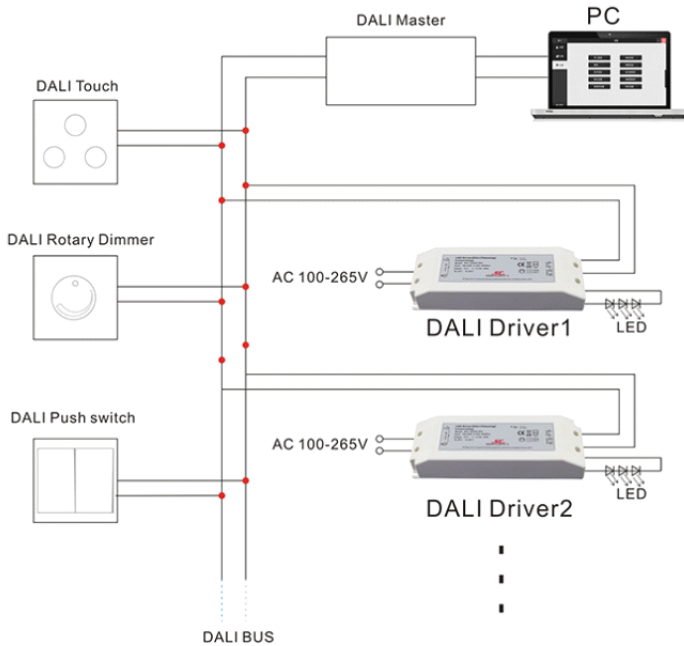

※Please refer to Diagram 1. Connect the Dali signal line to the Dali bus of the controller (the Dali Master). After Dali Master scanning and address assignment, the driver can be successfully dimmed.

※Notice:In the market, some DALI controllers has bus-powered functions .If not,please add an extra power supply.(DALI Power).

※Any incorrect connecting of signal line and output line would damage the master.

Operation Reference No.2:

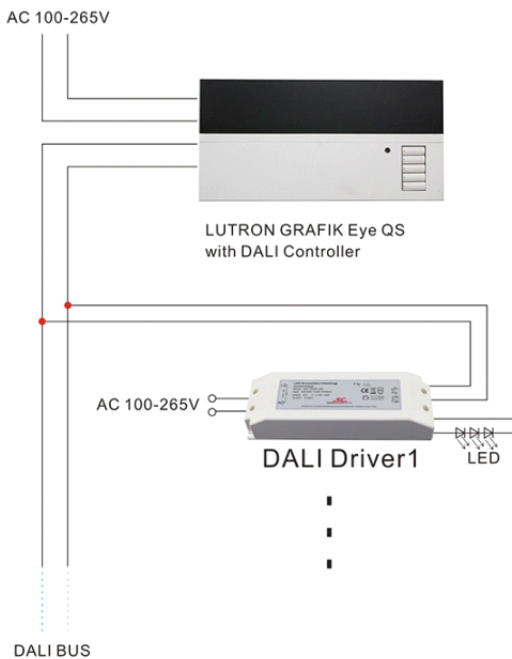

※Please refer to Diagram 2. Connect the Dali signal line to the Dali controller.

DALI Dimmable driver - constant voltage Series 45W

Operation Reference No.3:

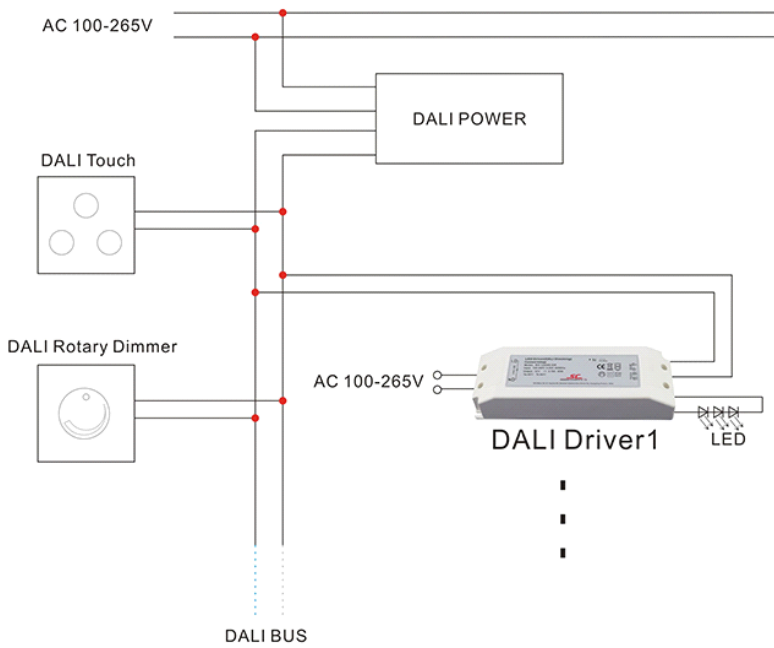

※Please refer to Diagram 3 Connect the Dali signal line to the Dali dimmers.

Derating Curve

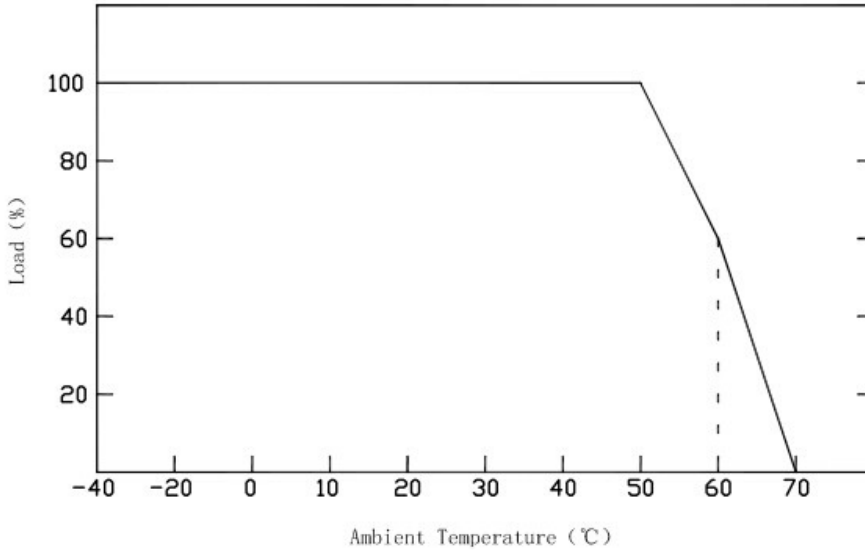

※To extend their life, please refer to the Derating Curve and derate according to the temperature.

Instruction:

- 1)This driver should be installed by qualified and professional person;
- 2)Please make sure the transformer is installed with adequate ventilation around it to allow for heat dissipation.
- 3)Ensure that wiring is correct before test in order to avoid light and power supply damage;
- 4)If driver Cannot work normally, don't maintain privately; Have any question, please contact Shengchang.

Any other question please feel free to contact ZHUHAI SHENGCHANG ELECTRONICS CO.,LTD